



<https://doi.org/10.11646/zootaxa.4399.1.2>

<http://zoobank.org/urn:lsid:zoobank.org:pub:43FE3C2A-6413-4B9C-88B3-6F27F1B7035F>

Cryptic species among bumblebee mimics: an unrecognized *Hemaris* hawkmoth (Lepidoptera: Sphingidae) in eastern North America

B. CHRISTIAN SCHMIDT

Canadian National Collection of Insects, Arachnids, and Nematodes, Ottawa Research and Development Centre, Agriculture and Agri-Food Canada, Ottawa, Ontario, Canada. E-mail: christian.schmidt@agr.gc.ca

Abstract

Through integrating molecular, morphological and natural history evidence, nominal *Hemaris diffinis* (Boisduval) of eastern North America is shown to include a second, cryptic species, *Hemaris aethra* (Strecker) **stat. rev.** Despite highly divergent mtDNA sequences and differing larval phenotypes, genitalic morphology, habitat and larval host plants, adults of *H. aethra* and sympatric *H. diffinis* are externally so similar that *H. aethra* has remained unrecognized for over a century. With a more northerly distribution than *H. diffinis*, *H. aethra* occurs from Manitoba to Nova Scotia and adjacent parts of the United States, the two species occurring in strict sympatry in eastern Ontario and likely other regions. Co-mimicry of *Bombus* Latreille bumblebee models has likely resulted in phenotypic convergence of *H. diffinis* and *H. aethra*, as the two do not appear to be sister taxa, the latter instead being more closely related to the western species *H. thetis* (Boisduval). The larvae of *H. aethra* are illustrated for the first time, together with diagnostic images and comparisons of adults. Lectotypes are designated for *Hemaris tenuis* Grote and *Hemaris marginalis* Grote.

Key words: Co-mimicry, *Bombus* mimicry, Cryptic species, DNA barcode, Caprifoliaceae, *Diervilla lonicera*, *Lonicera tatarica*

Introduction

Hawk moths (Sphingidae) include some of the most striking examples of Batesian mimics of Hymenopteran models. Within the subfamily Macroglossinae alone, at least two separate lineages (Kawahara et al. 2009) mimic bumblebees (*Bombus* Latreille), *i.e.* *Euproserpinus flavofasciata* (Walker) (Rubinoff & Leroux 2008) and *Hemaris Dalman* (Kitching & Cadiou 2000). Other unrelated genera such as *Sataspes* Moore (Smerinthinae: Smerinthini) mimic *Xylocopa* Latreille carpenter bees (Riotte 1981). Diurnality, frequent flower-nectar visitation, combined with a yellow/orange and brown/black abdominal pattern and scale-free, transparent wings render members of the genus *Hemaris* exquisite behavioural and morphological bumblebee mimics. With about 20 species (Kitching & Cadiou 2000), *Hemaris* is the most speciose group of *Bombus*-mimics in the northern hemisphere. Four *Hemaris* species are recognized in North America (Tuttle 2007; Schmidt 2009). Subtle interspecific differences combined with considerable geographic and seasonal variation in the *Hemaris diffinis* (Boisduval) group, previously comprising *H. diffinis* and *H. thetis* (Boisduval), have resulted in changing taxonomic concepts over time (Schmidt 2009).

Hemaris diffinis exhibits seasonal and geographic variation across its range, the numerous junior taxonomic synonyms attesting to this phenotypic variability. Early authors named new taxa based on external differences of adults such as forewing markings and abdominal colour pattern, until these differences were established as representing variation within the same species (*e.g.*, Smyth 1900). Nevertheless, Barnes & McDunnough (1910) recognized two separate taxa comprising eastern North American *H. diffinis*: subspecies *aethra* occurring from Maine to northern Ontario, and the nominate subspecies *diffinis* to the south. Barnes & McDunnough (1910) were well aware of the seasonal and regional variation of *diffinis*, and were careful to assign named spring and summer forms to either subspecies. Their account differed from the earlier concept of Rothschild & Jordan (1903) in their seminal work on the global sphingid fauna, who did not recognize subspecies within *H. diffinis*. Prevalent usage

favoured Rothschild and Jordan's concept for the next century, which was further entrenched in subsequent sphingid monographs (Hodges 1971; Tuttle 2007). However, preliminary work on mitogenomic variation within nominal *H. diffinis* of eastern North America revealed deep splits in COI gene sequences (Schmidt 2009), prompting the current study.

Hemaris diffinis in eastern Ontario displays two divergent groups of DNA barcodes, which led me to investigate the immature stages, host plants, habitats, phenology and adult morphology of the respective mitogenomic groups. Although adults are externally very similar and the occurrence of divergent groups within a single species is documented in other North American Lepidoptera (Zahiri et al. 2017), the concordant variation of all other characters sets unequivocally indicate that a second, unrecognized species of *Hemaris* occurs sympatrically with *H. diffinis* in eastern Canada and north-eastern USA. The name that applies to this species is here determined to be *H. aethra* (Strecker, 1875), **stat. rev.**

Methods and materials

Adults were sampled primarily by hand net, usually while taking nectar at flowers during the day; a few specimens were also collected with Malaise traps. Larvae were collected by visual searches and by tapping target plants onto a beat sheet (Wagner 2005). Larvae were reared at ambient indoor temperatures in screened glass containers provided with ~7cm of sand. Photographs of *Hemaris* available on BugGuide.net and iNaturalist.org were also examined (Appendix A). Adult genitalia were prepared following the methods of Lafontaine (2004). Cleaned, stained genitalia were stored and examined in 30% ethanol, and slide-mounted in Euparal before being photographed using a Nikon D200 digital camera. Microscopic measurements and genitalic images were taken using a Leica M205C and Leica Application Suite 4.8, and processed in Adobe PhotoShop. Maps were created using SimpleMappr (<http://www.simplemappr.net>).

Repository abbreviations are as follows:

NHMUK—The Natural History Museum (formerly British Museum [Natural History]), London.

CMNH—Carnegie Museum of Natural History, Pittsburgh, Pennsylvania.

CNC—Canadian National Collection of Insects, Arachnids and Nematodes, Ottawa, Canada.

FMNH—Field Museum of Natural History, Chicago, Illinois.

MEM—Mississippi Entomology Museum, Starkville, Mississippi.

ROM—Royal Ontario Museum, Toronto, Ontario.

USNM—National Museum of Natural History (formerly United States National Museum), Washington, D.C.

Approximately 1,200 museum specimens were examined from the collections of the CNC, CUIC, MEM and ROM.

DNA extraction, PCR amplification, and sequencing of the COI barcode region were performed at the Canadian Centre for DNA Barcoding and followed standard protocols (Hebert et al. 2013; <http://www.ccdb.ca/resources.php>). Resulting data were managed and analyzed using BOLD (Barcode of Life Data Systems; Ratnasingham & Hebert 2007), available at <http://v4.boldsystems.org/>. Mitogenomic divergence was calculated based on Kimura 2-Parameter (K2P) distances of COI barcodes (Table 1), using MEGA 7.0 (<http://www.megasoftware.net>). Molecular phylogenetic analysis was conducted using the Maximum Likelihood and Bayesian Inference methods, with initial ML tree(s) obtained through Neighbor-Join and BioNJ algorithms as implemented in MEGA 7.0 (Kumar et al. 2016). Bayesian analyses were carried out using MrBayes v3.2.6 (Huelsenbeck & Ronquist 2001) with a generalised time reversible model using gamma-distributed rate variation and invariable sites (GTR+ Γ +I). The analysis was run for 100000 runs with a 25% burn-in, standard deviation of split frequencies < 0.01, and a final potential scale reduction factor (PSRF) > 0.9999. Fifty-three barcode sequences of *H. diffinis* were available on BOLD, representing 16 different haplotypes. Phylogenetic analysis was based on one exemplar of each haplotype, with the addition of other haplotypes representing *H. thetis* (3 haplotypes) and *H. thysbe* (1 haplotype), the latter used as an outgroup (Appendix A). There were a total of 654 nucleotide positions in the final dataset.

TABLE 1. DNA sequence divergence between haplotype groups of *Hemaris*, based on the barcode fragment of the COI gene. The percent divergence from averaging over all sequence pairs between groups is shown, based on analyses using the Kimura 2-parameter model. The analysis involved the 17 haplotypes shown in Figure 1.

	<i>H. thysbe</i>	D1 (<i>H. diffinis</i>)	D2 (<i>H. diffinis</i>)	A (<i>H. aethra</i>)
D1 (<i>H. diffinis</i>)	6.56	-		
D2 (<i>H. diffinis</i>)	5.87	3.45	-	
A (<i>H. aethra</i>)	6.64	3.87	3.68	-
<i>H. thetis</i>	5.86	2.78	2.62	4.09

Results and discussion

COI sequence variation of eastern North American *H. diffinis*-group populations segregates into three clades (Fig. 1), here termed D1, D2 (*H. diffinis*) and A (*H. aethra*; see ‘Nomenclature’ section for taxon name usage). These clades differ between 3.45% and 3.87% (Table 1), compared to 2.62–4.09% for *tethis* vs. *diffinis* + *aethra* (D1+D2+A), and 5.9–6.6% for *thysbe* vs. *diffinis*+ *aethra*+*tethis* (Table 1). The three eastern groups and the western species *H. thetis* each form well-supported clades. The *aethra* clade is on average slightly more similar to the D1 and D2 *H. diffinis* clades (3.87% and 3.86%) than it is to *H. thetis*, but the topology of the entire group based on the COI barcode fragment is unresolved (Fig.1). *Hemaris aethra* and *H. thetis* each formed well-supported clades, while the two *H. diffinis* clades were each well supported, but there was no support for a combined *H. diffinis* clade (Fig. 1).

The most widely distributed clade is D1, occurring from the northwestern Great Plains (Alberta and Saskatchewan) to southern Québec and southward throughout the range of *H. diffinis* (Fig. 2). This clade includes the Great Plains *H. diffinis* adult phenotype which has more extensive yellow setation on the dorsum of abdominal segments 4 and 5 (Schmidt 2009), and also includes the dark-abdomen phenotype that occurs east of the Appalachian Mountains. The original description of *H. diffinis* was based on the latter phenotype (Schmidt 2009). This mtDNA clade is therefore unequivocally associated with the taxon *H. diffinis*, in the strictest sense.

Given the geographically widespread distribution of clade D1, it was unexpected that no Ontario populations belonged to this clade, these samples instead falling into either clade D2 or A (Fig. 2). The presence of D2 haplotypes in populations from adjacent regions of Québec, New York and Michigan is probable, but additional sampling is needed to confirm this. Larvae of the D2 clade were found on *Symphoricarpos alba* and *Lonicera tatarica*, and subsequently photographed, reared and sequenced to confirm the association of morphological (larval and adult) and molecular data. A geographic distribution that is seemingly endemic to the Great Lakes region is intriguing and warrants more in-depth study, as does the significance of the mitogenomic divergence of this group. This clade potentially indicates yet another cryptic species, but morphologically both larvae and adults of D2 populations were indistinguishable from nominate *H. diffinis* (Figs 3–7) and were therefore identified as such. Additional, nuclear genetic markers should be examined to fully resolve the nature of this mitogenomic variation.

The provenance of clade A samples ranged from west-central Ontario east to Nova Scotia, in addition to three isolated samples from Oklahoma and Arkansas (Fig. 2). Field work in eastern Ontario revealed that geographically proximate sites (18 km apart) which differed in geology and habitat type, were inhabited by *Hemaris* of two separate clades, D2 and A. The complex geology of eastern Ontario consists of two contrasting geologic histories, an ancient pluton dominated by granite that forms the Canadian Shield, and a geologically more recent sedimentary plain, primarily limestone of Ordovician age (Chapman & Putnam 1984). The underlying bedrock often dictates considerably different landforms and plant communities, particularly evident when contrasting granite barrens to limestone alvars (Catling & Brownell 1999a,b). D2 (*H. diffinis*) populations occurred primarily in habitats underlain by sedimentary bedrock, where the most common larval hostplants are *S. alba* and *Lonicera* species. In contrast, most *Hemaris* samples of clade A came from sites with igneous bedrock plant communities, where *Diervilla lonicera* is the most common of the plants known to be *H. diffinis* hosts. Both species can however occur in sympatry at some sites, such as eastern Lanark County and Manitoulin Island (Figure 2; Appendix A). Differences in habitat preference provided the first clues to potential biological differences between the two haplotype clades. Photographs of *Hemaris* “*diffinis*” larvae (CNC photographic slide collection and J. Dombroskie personal

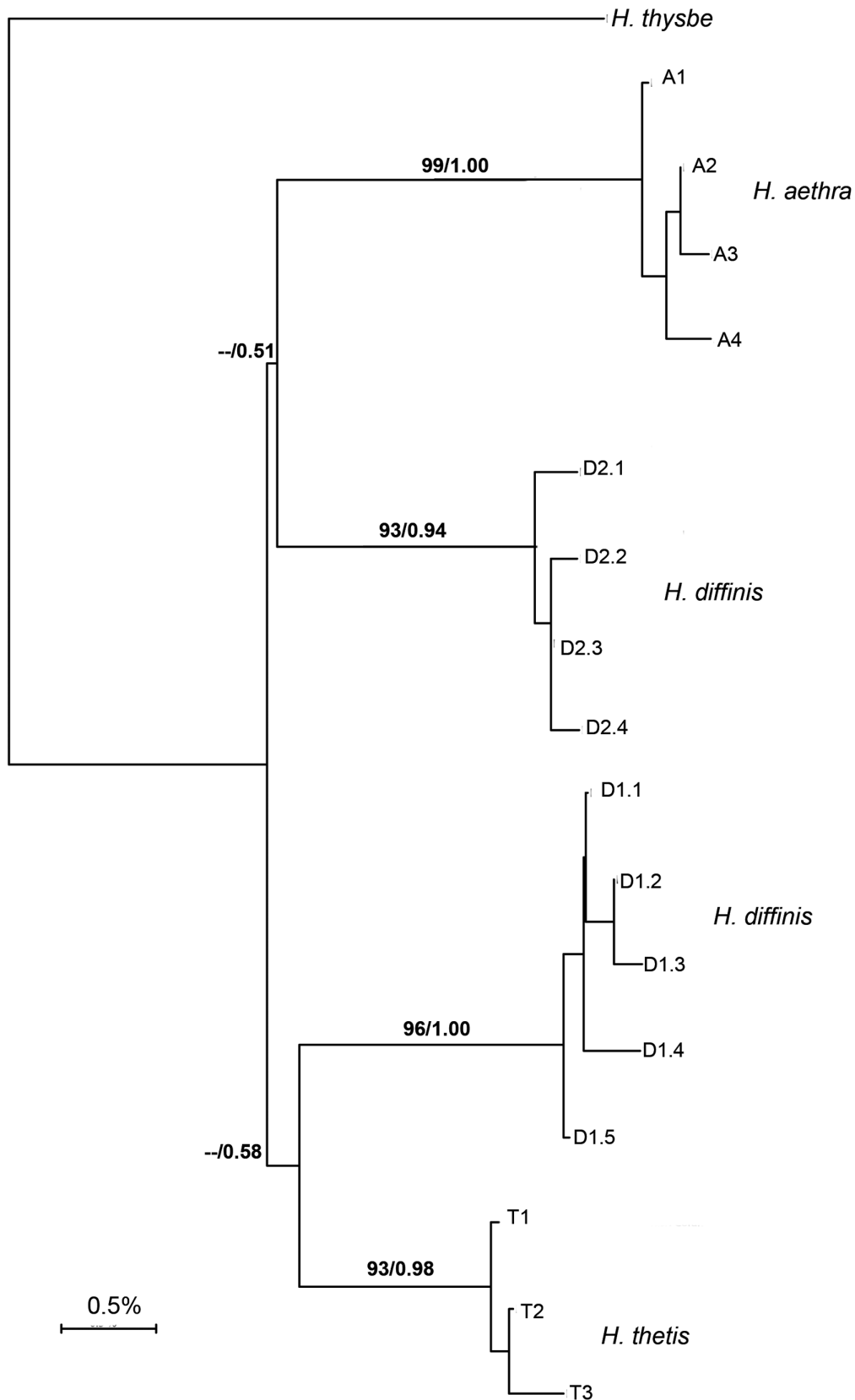

FIGURE 1. Molecular phylogeny of representative *Hemaris diffinis*-group COI ‘barcode’ haplotypes, as inferred using Maximum Likelihood and Bayesian Inference methods. Bootstrap values (500 replicates) and posterior probabilities are shown above branches. *Hemaris diffinis* (*sensu stricto*) haplotypes are represented by two clades, D1.x and D2.x, *H. aethra* (A.x) and *H. thetis* (T.x) by one clade each.

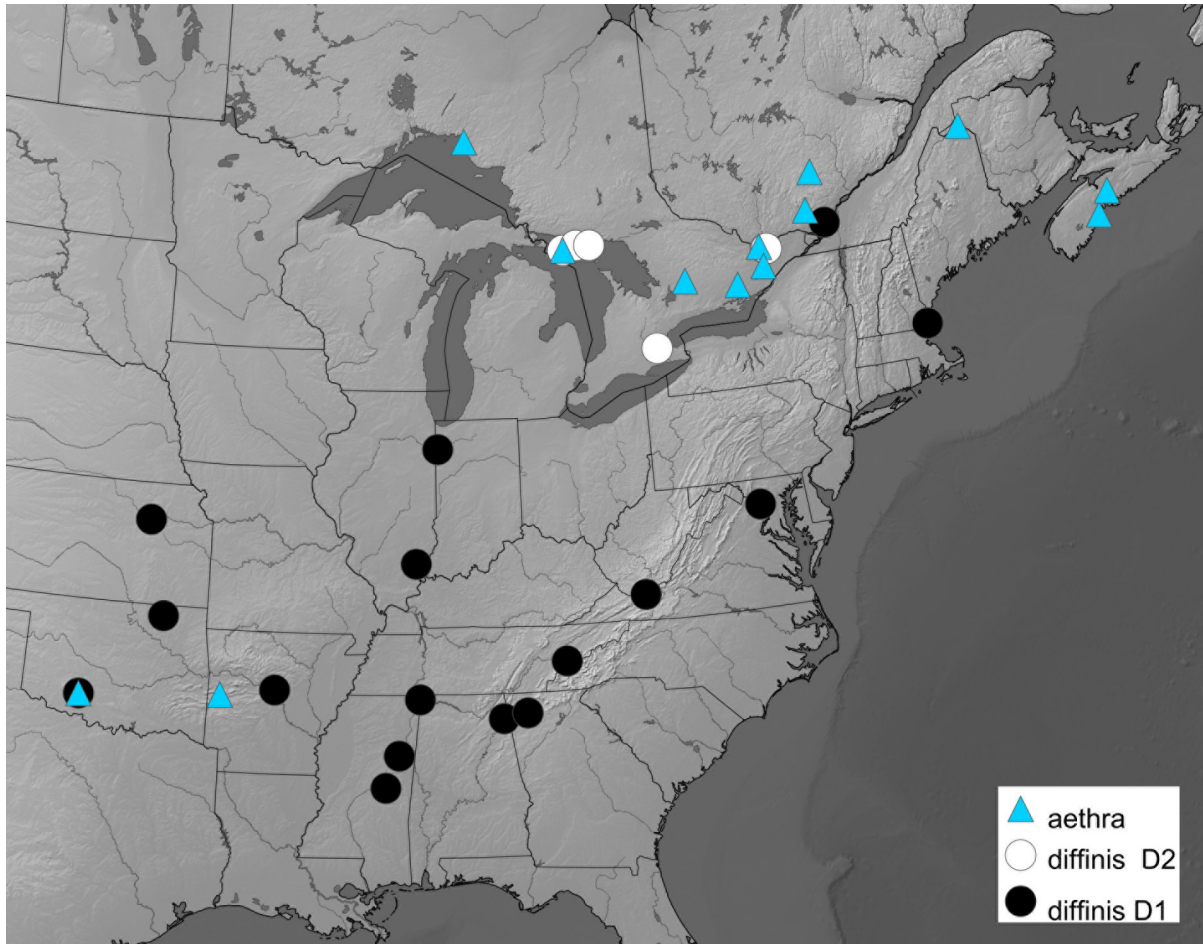

FIGURE 2. Geographic distribution of *Hemaris diffinis*-group mtDNA clades in eastern North America. *Hemaris diffinis* is represented by two haplotypes of two clades, D1 (black circles) and D2 (white circles), and *H. aethra* is represented by a single clade (triangles).

collection) provided additional clues: Ontario larvae found on *Diervilla lonicera* exhibited red rather than the black spiracles typical of *H. diffinis*. Directed searches on *D. lonicera* yielded a number of larvae, subsequently reared, photographed and sequenced, confirming the association between distinctive larvae, host plants and divergent mtDNA sequence. A larger sample size also confirmed subtle but consistent differences in adult coloration and genitalic structure, discussed below in the “Diagnosis” section. To ascertain which, if any, of the available taxon names that are currently junior subjective synonyms of *H. diffinis* apply to the cryptic species represented by clade A, the original descriptions, historic literature and type specimens were reviewed, as detailed in the “Nomenclature” section below. A review of the *H. diffinis* names shows that only the taxon *H. aethra* Strecker, 1875 applies to this species.

Three samples of clade A haplotypes from Oklahoma and Arkansas suggest the intriguing possibility that the species may be more geographically widespread, or disjunct near the Ozark Plateau. The limited sample size did not reveal adult phenotypic differences of these specimens compared to southern *H. diffinis*, nor were they like northern *H. aethra*. All specimens were males, precluding comparison of diagnostic female genitalic structure. As there is currently no other indication that *aethra* occurs this far south (or that it is associated with plants outside the range of *Diervilla*), the possibility of mtDNA introgression or ancestral polymorphism within nominate *H. diffinis* of this region must be considered, but clearly these populations warrant careful scrutiny.

Diagnosis of *Hemaris aethra*

Adult. External differences between *H. aethra* and *diffinis* are subtle, and usually difficult to evaluate without

comparative specimens in hand; photographs of live specimens are difficult or impossible to determine. Overall, *H. aethra* adults appear slightly larger and more robust with an overall richer orange-yellow tone compared to *H. diffinis* in corresponding spring vs summer broods (Figs. 3–6), and with a slightly greater extent of red scaling on the forewing apex and hindwing anal margin (Table 2).

TABLE 2. Comparison of diagnostic differences between *H. aethra* and *H. diffinis*, based on populations in eastern Canada.

Trait	<i>H. aethra</i>	<i>H. diffinis</i>
head width ¹	3.82 mm	3.52 mm
Forewing length (1 st generation) ²	20.7 mm	18.2 mm
Forewing length (2 nd generation) ²	21.6 mm	19.6 mm
forewing apex	reddish-brown patch larger, occupying 50% or more of R4-R5 cell	brown patch smaller, usually occupying <50% of R4-R5 cell
Hindwing anal margin	reddish brown scaling more extensive	reddish brown scaling usually limited to inner margin
dorsal-medial vestiture	richer orange-brown, dorsal thorax contrasting with olive-brown tegula	olive tan-brown, with less colour contrast between thorax dorsum and tegula
female postvaginal plate	0.8-1.0x as wide as long	0.5-0.7x as wide as long

¹ maximum width including eye.

² males (n = 6); northern univoltine populations of *H. aethra* do not differ significantly from those of 1st generation bivoltine populations.

Maximum head width is 8% wider than *H. diffinis* (Table 2), and forewing length is 14% greater, *i.e.* 35–36% overall greater wing area than *H. diffinis*. The coloration of the dorsal vestiture of *H. aethra* differs in having a straw-yellow rather than blonde-buff dorsolateral line. Diagnostic differences in adult vestiture are difficult or impossible to discern in flight-worn individuals. Slight differences in forewing markings are also evident. The forewing apex of *H. aethra* has a larger reddish-brown patch that usually covers half or more of the scaled marginal area delimited by veins R4 and R5. The reddish-brown scaling of the hindwing anal margin is also more extensive, giving the hindwing margin an overall brighter appearance. Unlike *H. diffinis*, the forewing marginal band is not noticeably thinner in spring versus summer individuals (compare Figs. 3–5 versus Figs. 4–6), so seasonal variation appears to be less pronounced in *H. aethra*. The dorsal and medial vestiture of the thorax and abdomen differs from *H. diffinis* in being a richer orange-brown dorso-laterally, with the dorso-medial thorax slightly more contrasting relative to the olive-brown tegulae. Summer *H. aethra* specimens differ from those of the spring brood in being slightly larger (Table 2), and with less extensive pale dorsolateral setae, the dorsum of A5 is also darker overall. No consistent male genitalic differences between *H. aethra* and *H. diffinis* were observed. Females differ structurally in the shape of the postvaginal plate, which appears as a rounded square in *H. aethra*, (0.8–1.0x as wide as long) and narrow in *H. diffinis* (0.5–0.7x as wide as long), but less quadrate and more off-center than in *H. thetis* (Fig. 12).

Literature references to *H. aethra* are few; Barnes & McDunnough (1910) correctly diagnosed the taxon (but as a subspecies of *H. diffinis*). The specimen illustrated by Hodges (1971) on plate II, figure 1 and that illustrated by Tuttle (2007) on plate 5, figure 5 as *H. diffinis* are both *H. aethra*, and likely also the specimen illustrated by Handfield (2011).

Larva. The larva of *H. aethra* is distinctive: it is the only North American *Hemaris* with bright red spiracles, a yellow prothoracic collar and a pink-purple caudal horn with black apex (Fig. 7). By comparison the spiracles of *H. diffinis* are invariably black (Fig. 8), and yellow-orange in *H. thetis*. The base of the caudal horn is pinkish-purple, occasionally yellow grading into pinkish edging (Fig. 7a), unlike the bright yellow base of *H. diffinis* (Fig. 8). Neither the brown morph (Fig. 8a) nor the bicolored green/dark-brown morph found in *H. diffinis* and *thetis* have been found in *H. aethra*. The apex of the horn is often curved slightly caudad, while that of *H. diffinis* is often curved forward (Tuttle 2007), but this was not a consistently diagnostic trait in the material reared during this study. Despite the moderate body of historical literature describing *H. diffinis* larvae, I could find no accounts ascribable to *H. aethra* larvae.



FIGURES 3–4. Comparison of spring-brood adults of *Hemaris diffinis* (**Fig. 3**) and *H. aethra* (**Fig. 4**) from eastern Canada. **3a.** ON: Ottawa Dist., Bells Corners, Timm Dr., 29.Apr.2010, voucher # CNCLEP 140388; **3b.** ON: Lanark Co., California Rd. hydro cut, 24.May.2017, voucher # CNCLEP 140389; **3c.** same data as (3a), voucher # CNCLEP 140390; **3d.** same locality as (3a), 13.May.2009 DNA voucher # CNCLEP 62975. *Hemaris aethra* (**Fig. 4**): **4a.** NB: Madawaska Co., Edmunston, 30.May.2006, DNA voucher # CNCLEP 41278; **4b.** ON: Ottawa Dist., Dolan Hwy at Carp Ridge, 7.May.2012, DNA voucher # CNCLEP 92236; **4c.** same data as (4c), DNA voucher # CNCLEP 92235; **4d.** ON: Lanark Co., Bellamy Rd at hydro cut, 9.Jun.2017, voucher # CNCLEP 140384.



FIGURES 5–6. Comparison of summer-brood adults of *Hemaris diffinis* (**Fig. 5**) and *H. aethra* (**Fig. 6**) from eastern Canada. **5a.** ON: Ottawa Dist., Bells Corners, Timm Dr., 15.Jul.2016, voucher # CNCLEP 140391; **5b.** ON: Lanark Co., Maberly, Old Brooke Rd., 26.Jul.2017, voucher # CNCLEP 140392; **5c.** same data as (5a), voucher # CNCLEP 120070; **5d.** same data as (5a), voucher # CNCLEP 140383; **6a.** ON: Ottawa Dist., Dolan Hwy at Carp Ridge, ex larva on *Diervilla lonicera* 20.Jun.2016, emgd. 14.Jul.2016, voucher # CNCLEP 140385; **6b.** same data as (6a), voucher # CNCLEP 140386; **6c.** same data as (6a), voucher # CNCLEP 140387; **6d.** same data as (6a), voucher # CNCLEP 140393.



FIGURES 7–8. Comparison of *H. aethra* (**Fig. 7**) and *H. diffinis* (**Fig. 8**) larvae from Ontario, Canada. **7a.** ON: Ottawa Dist., Carp Hills, June 2016, ex *Diervilla lonicera*; **7b.** ON: Ottawa Dist., June 1979, ex *D. lonicera*; **7c.** ON: Lanark Co., Almonte, June 1989, ex *D. lonicera*; **7d.** same data as (7a); **8a.** ON: Ottawa Dist., Bells Corners, Timm Dr., August 2011, ex *Lonicera tatarica*; **8b.** ON: Lanark Co., Christie Lake, June 2015, ex *Symphoricarpos alba*; **8c.** same data as (8a).

Biology. To date, the only known larval host plant of *H. aethra* is *Diervilla lonicera*, based on four separate larval collections in eastern Ontario. The geographic distribution of *H. aethra* is entirely within the range of *D. lonicera* (Fig. 10). Conversely, *H. aethra* is absent from more xeric habitats where *Diervilla* is rare or absent, but *Symphoricarpos* is common. Native *Lonicera* species are much less common than *Diervilla* at sites where *H. aethra* occurs, but this genus may also serve as a larval host, as it does for *H. diffinis*. By comparison, *H. diffinis* larvae in Ontario are most commonly found on *S. albus*, the only native species of *Symphoricarpos* in the study area. An early instar *Hemaris* suspected to be *H. diffinis* was also found on *L. dioica* (the larva died in the first instar). In somewhat weedy habitats such as old fields, particularly in dry, rocky situations, larvae of *diffinis* can be

relatively common on the introduced invasive *L. tatarica* L. Both *Lonicera* and *Symphoricarpos* are common hosts of *H. diffinis* in other parts of the eastern range (Tuttle 2007; Wagner 2005); Smyth (1900) also gives *Triosteum perfoliatum* Adult *H. aethra* have been observed at flowers of *Vaccinium*, *Chichory*, and *L. tatarica*.

Half of the 16 larvae collected in late June produced adults a month later in late July, whereas the remainder entered pupal diapause. In contrast, none of the 20+ spring brood larvae of *H. diffinis* entered pupal diapause. It therefore appears that the second, summer generation of *H. aethra* is only partial in eastern Ontario. The generally later spring flight dates from northern and central Ontario indicate that *H. aethra* is univoltine further north: nearly all records are from June, peaking in the last two weeks, and a few records extending into mid-July. In southeastern Ontario, there is an earlier spring flight and another flight in summer, with extreme flight dates from early May to early August; most records are from early to late June, and again from mid-July to early August.

Habitat and Distribution. Compared to the generally more xeric savannah-like habitats such as old fields, alvars and barrens inhabited by *H. diffinis*, *H. aethra* favors more mesic, open deciduous forest habitats, especially with natural openings on igneous bedrock. This may be indicative of host plant requirements as it parallels the distribution of *Diervilla lonicera* (Fig. 10). In Ontario *H. aethra* is not known from south of the Canadian Shield, a region underlain by igneous bedrock with *D. lonicera* locally abundant; similarly, *Diervilla* can be a dominant subshrub in parts of the Maritime Provinces (R. Webster, pers. comm.). *Diervilla lonicera* ranges southward along the Appalachian mountain chain, but there is currently no evidence that *H. aethra* does so (Fig. 9). Although habitat preferences between *H. aethra* versus *H. diffinis* exist, the two can occur in strict sympatry where habitat conditions permit; for example, the Christina Bay site on Manitoulin Island and near Pakenham, Lanark County, Ontario (Appendix A).

Specimens of *H. aethra* were examined from Manitoba, Ontario, Québec, New Brunswick, Nova Scotia, Michigan and New York (Fig. 9), and the species likely occur throughout the northern Great Lakes region. The only confirmed records for the United States are for northern New York (Franklin Co.) and northern Michigan (Cheboygan Co.); however, photographs of what is probably this species include one from Lake County, Minnesota (<https://www.inaturalist.org/observations/7011536>) and another on the Québec/New Hampshire border (<https://www.inaturalist.org/observations/7051935>). It almost certainly occurs throughout northern Minnesota, Wisconsin, Michigan, Vermont, Maine and perhaps southward into the northern Appalachians. Barnes & McDunnough (1910) cite specimens of “*Hemaris diffinis aethra*” from Maine. Due to the difficulty in identifying adults from photographs, particularly live individuals, new occurrences (especially range extensions) should be verified by photographs of larvae and/or vouchered specimens.

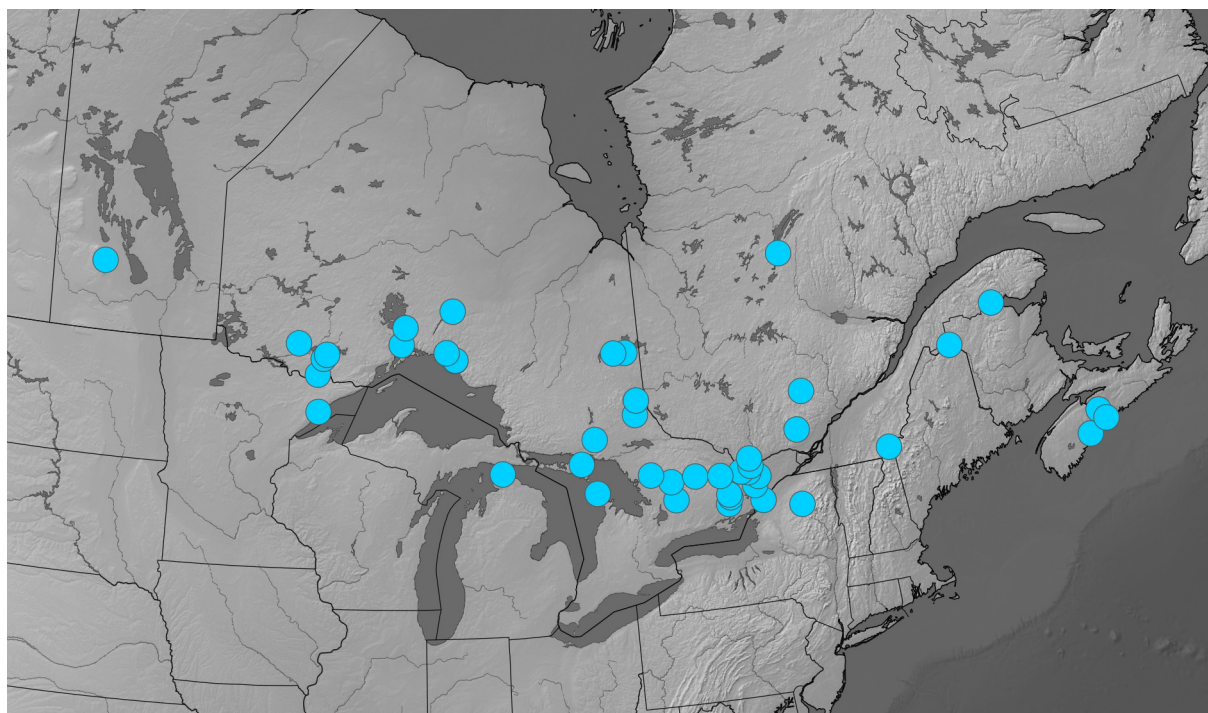

FIGURE 9. Distribution of examined specimens of *H. aethra*. Associated specimen data is provided in Appendix 1.

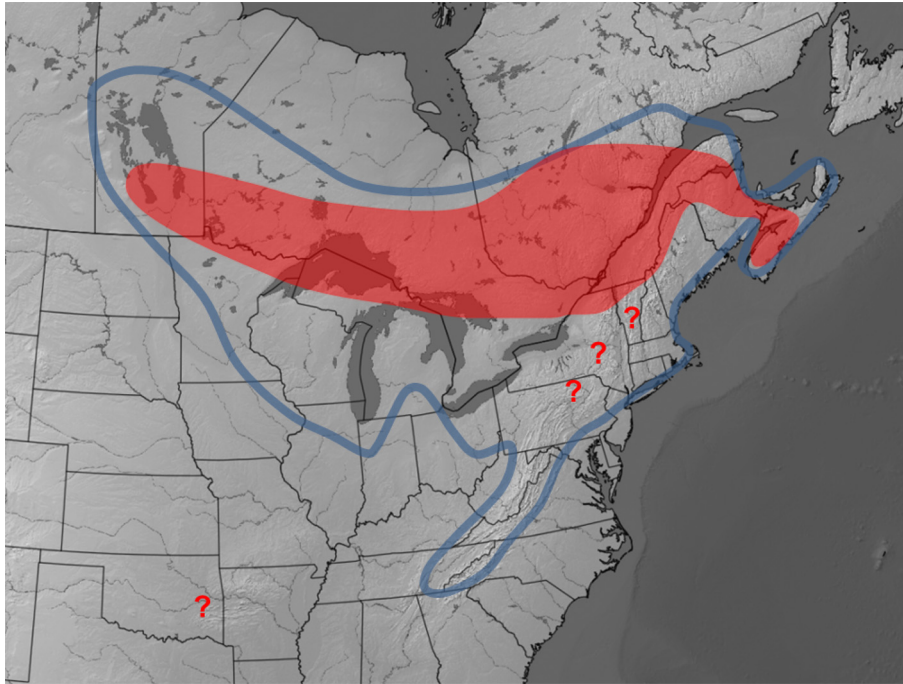

FIGURE 10. Comparison of the minimum range of *H. aethra* (red) and the distribution of its larval host plant, *Diervilla lonicera* (blue). Range of *H. aethra* is based on minimum shape incorporating examined specimens (Fig. 8), with unverified or potential records indicated by questions marks. Range of *D. lonicera* is based on information in Kartesz (2015) and Canadensys Explorer (<http://data2.canadensys.net>).

Nomenclature

Hemaris aethra (Strecker, 1875) stat. rev.

Macroglossa aethra Strecker, 1875: 107, pl. XIII, fig. 2.

Type locality: Montréal [Québec], Canada. [FMNH; Fig. 11]

Comparison of series of specimens from both spring and summer broods of the two eastern species studied here show that three diagnostic traits of the adult phenotype of the cryptic species (Table 2) are consistent with the holotype of *H. aethra* (Fig. 11): overall larger size (wingspan 48 mm); straw-yellow dorsolateral vestiture that extends into segment A4; and more extensive reddish-brown patch of the forewing apex. Also, the type locality of Montréal, Québec is in the central part of the species' range. The holotype examined closely matches the illustration in Strecker's (1875) original description (Fig. 11). Barnes & McDunnough (1910) recognized *aethra* as a subspecies distinct from other eastern North American *diffinis* (based solely on adult phenotype), and arranged *diffinis* into parapatric subspecies, with *aethra* from northern Ontario through Québec into Maine, and *diffinis* to the south. Barnes & McDunnough also state that *aethra* is larger with more yellow vestiture and more reddish scaling in the forewing apex. The characterization of *Hemaris diffinis aethra* by Barnes and McDunnough is therefore also fully consistent with the cryptic species identified here.

Revised synonymy of *Hemaris diffinis* (Boisduval)

Hemaris diffinis (Boisduval)

Macroglossa [sic] *diffinis* Boisduval, 1836: pl. 15, fig. 2.

Type locality: "Amerique septentrionale" [southeastern Atlantic seaboard, possibly Georgia, USA]. [CMNH]
The provenance and identity of the *diffinis* type material was discussed by Schmidt (2009), and identifies the

southeastern US phenotype with the dark distal half of the abdomen as nominate *diffinis*. mtDNA barcodes (voucher # LEP041279, Appendix A) and larval phenotypes indicate that southeastern US populations are conspecific with other *diffinis* populations.



FIGURE 11. Illustration (top) from the original description of *Macroglossa aethra* (Strecker 1875), and the holotype specimen with associated labels (bottom), deposited in the Field Museum of Natural history (available at <http://collections-zoology.fieldmuseum.org/catalogue/804170>).

= *Sesia axillaris* Grote & Robinson, 1868: 180.

Type locality: “Texas (Belfrage)” [here restricted to the vicinity of Houston, Texas, USA] [FMNH].

Sesia axillaris was described based on four syntypes from Texas, originating from Gustav Wilhelm Belfrage, a well-known source of Texas insect specimens in the 1860s (Geiser 1933). Belfrage resided in the Houston area for several years until relocating to Bosque County in 1868 (Geiser 1933), the same year that Grote and Robinson described *axillaris*. It is unlikely that the specimens would have been received, examined, described and published by Grote and Robinson within the same year that Geiser moved to Bosque County, so the type locality of *axillaris* is therefore most likely the Houston area. The location of the *axillaris* syntypes is not known, but they may reside

in the FMNH, along with other Grote and Robinson types. *Axillaris* was described based on the forewing marginal band being wide and with a diffuse, dentate inner border. This phenotype was subsequently illustrated by Grote (1874), and has long been known to be part of the seasonal variation in *H. diffinis*, representing a summer form (Smyth 1900). This was again confirmed in this study through mtDNA, as a specimen of this phenotype (DNA voucher # NOC14993, Appendix A) shared haplotypes with other *diffinis* forms (Fig. 1).

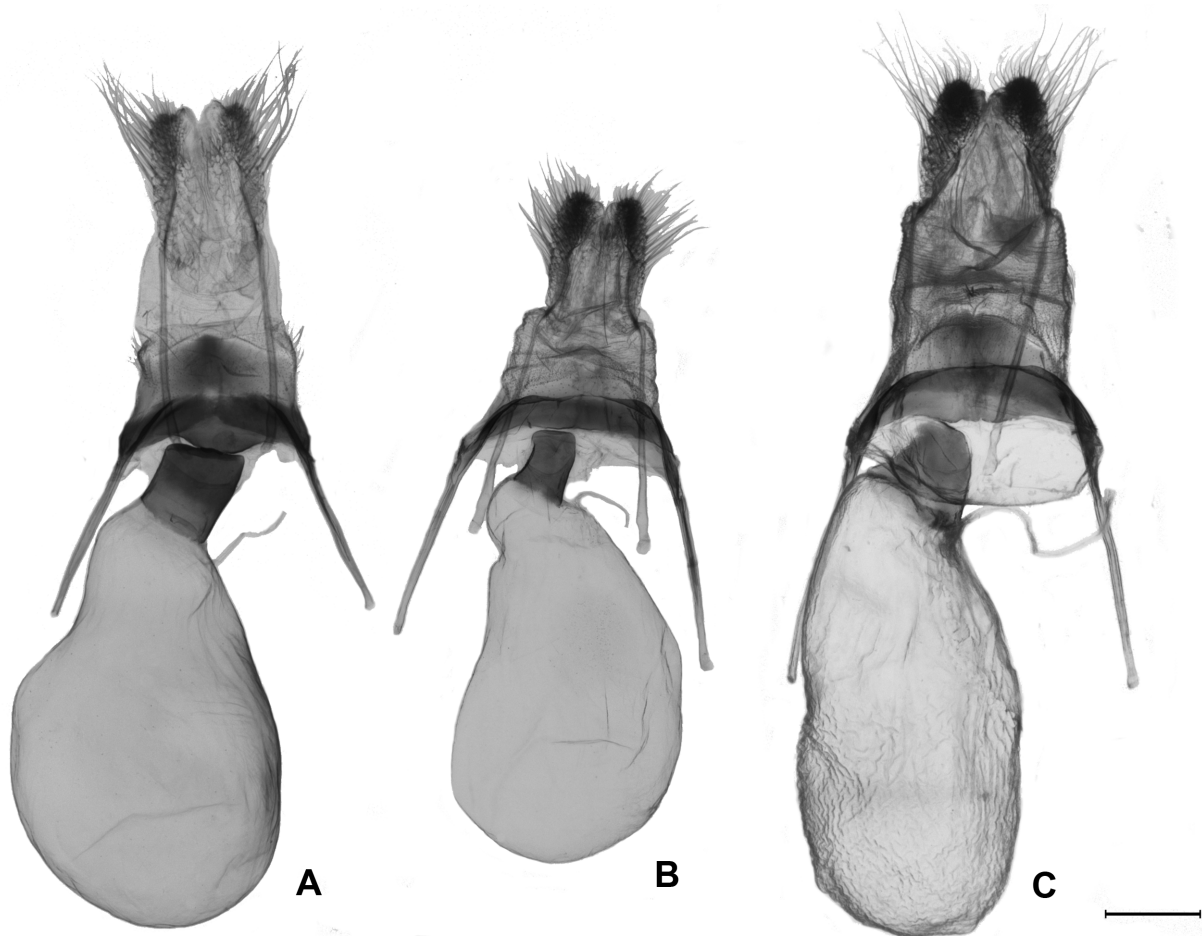

FIGURE 12. Female genitalia of *Hemaris thetis* (A), *H. diffinis* (B) and *H. aethra* (C). Scale bar equals 1 mm.

= *Hemaris tenuis* Grote, 1873: 4, pl. 1, fig. 6.

Type locality: “West Farms, N.Y. and Berks Co., Pennsylvania” [here restricted to West Farms, Bronx Co., New York] [FMNH].

Grote described *tenuis* from an unspecified number of syntypes, but at least two specimens were examined by him as the specimen source is given as West Farms [Bronx Co.], New York and Berks County Pennsylvania. Although not currently known to occur there, the species here recognized as *aethra* could eventually be found in Berks County, PA, so there is a possibility that Grote’s syntypes included this species. The following female specimen in FMNH was examined, and is therefore designated as **lectotype**:

“*Hemaris / tenuis / Grote / Type.*”; *M. Tenuis / Grote / W. Farms N.Y. / orig. / Type / J. Angus*”; “West Farms / N.Y.”; “FMNH-INS / 0000 095 046””; “*Macroglossa tenuis / Grote / Pa., Berks Co.*” Strecker Colln. 25486 / Field Museum Nat. Hist.”; “Lepidoptera Type / Photograph No. 173 / Field Museum””; “PHOTOGRAPHED / Allie Stone Stone 2012 / KE EMu catalog””. The following red label will be added: “LECTOTYPE / *Hemaris tenuis / Grote, 1873 / B.C. Schmidt 2018*”.

The specimen is in moderate condition, with the left antenna glued on, and the right hindwing chipped at the anal angle. The type locality is therefore restricted to West Farms, Bronx Co., New York. Gall & Hawks (2002:

249) state that not all specimens from J. Angus of West Farms, New York were actually collected there, but without evidence to the contrary, the locality is here maintained as the type locality. The *tenuis* lectotype is comparatively small (wingspan 41 mm), with the narrow, even-bordered forewing margin (indicated by the name *tenuis*) of the spring brood, and nearly completely dark segments 4 and 5, all consistent with spring brood *diffinis* as opposed to *aethra*.

= ***Hemaris marginalis* Grote, 1873: 6, pl.1, fig.10.**

Type locality: “Michigan” [here restricted to southern Michigan, USA] [FMNH].

Grote described *marginalis* based on an unspecified number of syntypes from Michigan, but the collector of the type material is unknown and a specific locality is not given. The most probable provenance is southern Michigan, where several collectors resided in the mid to late 1800s, whereas northern Michigan’s Lepidoptera remained very poorly known (Newcomb 1913). A putative type specimen of *marginalis* in FMNH was examined. It represents the summer brood form of *H. diffinis* with a dentate inner border of the forewing marginal band, consistent with the original description. The dentate marginal band and the smoother, shorter vestiture occur only in summer brood individuals. The smaller size (44 mm wingspan), nearly completely dark abdominal segments 4 and 5 are consistent with *H. diffinis*, not *aethra*. However, *Hemaris aethra* almost certainly occurs in Michigan and as the identity and location of other potential syntypes of *marginalis* is unknown, the following specimen here is designated as **lectotype**:

“*Hemaris marginalis*” [in Grote’s handwriting?]; “*Macroglossa/Marginalis/Michigan. Grote*”; “*M. Marginalis/Grote/Orig./Type*”; “*Macroglossa marginalis / Grote / Michigan.*” Strecker Colln. 25504 / Field Museum Nat. Hist.”; Lepidoptera Type / Photograph No. 175 / Field Museum”; “FMNH-INS / 0000 095 048”; “PHOTOGRAPHED / Allie Stone 2012 / KE EMu catalog” The following red label will be added: “LECTOTYPE / *Hemaris marginalis* / Grote, 1873 / B.C. Schmidt 2018”. The specimen is in good condition except for a dorsally denuded thorax.

= ***Sesia grotei* Butler, 1874: 365.**

Type locality: “Texas (Belfrage)” [NHMUK].

As discussed under *axillaris*, G. W. Belfrage had resided in both Houston & Bosque County by 1874, so the *grotei* types may have come from either region (Belfrage also collected in west Texas but *diffinis* does not occur there). The taxon was based on the form with a dentate forewing marginal band. As for *axillaris*, the phenotype and type locality are consistent with *H. diffinis* rather than *aethra*.

= ***Macroglossa fumosa* Strecker, 1874: 93, pl. XIII, fig. 3.**

Type locality: Racine, Wisconsin [FMNH].

The name *fumosa* was proposed for a specimen with “smoky” wings, an appearance that is caused by the normally transparent areas of the wing being scale-covered; all *Hemaris* eclose from the pupa with the forewing entirely scale-covered, losing the scales from the transparent areas at first flight. Although Strecker was apparently not aware of this phenomenon, *fumosa* is an available name and it is still necessary to determine which species it applies to, as the type locality is potentially within the range of either species. The type locality is sometimes given as Albany, New York in the historical literature but the specimens were only reared at Albany, originating instead from Racine, Wisconsin (Grote 1874). The wing expanse of 4.44 cm (=1.75 in) and the two solid dark bands on abdominal segments 4 and 5, as indicated in the original description and consistent with the holotype, are typical of midwestern *diffinis* rather than *aethra*, and *fumosa* is correctly attributed to the synonymy of *diffinis*.

= ***Hemaris metathetis* Butler, 1876: 519.**

Type locality: Texas [NHMUK].

The name *metathetis* is the third proposed for *diffinis* collected in Texas by G. W. Belfrage, and the holotype was based on a spring brood specimen, of smaller size and with a narrower, non-dentate forewing marginal band

(Butler 1876). In describing a variant of the summer form *grotei*, Butler (1874) had mistakenly believed *axillaris* to be the spring form (Butler 1876). As discussed under *grotei* and *axillaris*, the types of *metathetis* could have come from either the Houston area or Bosque County.

= *Hemaris diffinis ariadne* Barnes & McDunnough, 1910: 201.

Type locality: “Denver, Colo. [Colorado]” [USNM].

The name *ariadne* was proposed for the Great Plains form of *diffinis*, which exhibits more yellow coloration on the dorsum of abdominal segments A4 and A5.

Conclusions

Concordant differences in COI gene sequence, adult and larval morphology, larval hostplant and biology show that a second, cryptic species, *H. aethra*, occurs together with true *H. diffinis* in northeastern North America. This is particularly surprising given that hawk moths are taxonomically well-known, and that *H. aethra* occurs in a well-studied region of North America. The historic recognition of the taxon *H. aethra* (as a subspecies), a name subsequently subsumed within supposed geographic variation of *H. diffinis* for the past century, also highlights the potential importance of recognizing subspecies as significant evolutionary units.

The larval colour pattern and female genitalic structure of *H. aethra* indicate a closer relationship to *H. thetis* than to *H. diffinis*. *Hemaris aethra* and *H. thetis* share a purplish caudal horn base, red (*aethra*) or yellow-orange (*thetis*) spiracles, and a wide postvaginal plate of the female genitalia. The similarities between *aethra* and *thetis* warrant considering the possibility of these two taxa being conspecific; however, the comparative larval, adult and mitogenomic differences together with an allopatric distribution in different biomes and different larval hosts, strongly favour recognizing *aethra* as a species distinct from *thetis*.

Despite being remarkably variable across its vast geographic distribution, *H. diffinis* and *H. aethra* are virtually identical externally where their ranges abut or overlap. This phenomenon also occurs at the western range limits of *H. diffinis*, where overlapping and adjacent populations of *H. thetis* are externally very similar (Schmidt 2009), albeit different from eastern *diffinis* phenotypes. Such geographic variation patterns suggest that co-mimicry of *Bombus* models may have shaped phenotypic evolution in the *Hemaris diffinis* group, a well-known phenomenon in Mullerian mimicry rings among tropical *Heliconius* butterflies (Mallet & Gilbert 1995, and references therein) but with few examples in the temperate fauna (but see for example Sbordoni et al. 1979). By comparison, *Hemaris* may represent a complex system of Batesian co-mimics of *Bombus* phenotypes, which similarly exhibit high intraspecific variation in color pattern, but with patterns conserved across species and dominant in different regions (Plowright & Owen 1980). The *H. diffinis* complex presents the opportunity as further test cases of these evolutionary processes.

Acknowledgements

Several colleagues kindly aided this study by providing technical support, specimens, photographs, or field assistance, and I thank James Adams, Jason Dombroskie, Hume Douglas, Jocelyn Gill, Henri Goulet, and Reza Zahiri. Jason Dombroskie and Jim Liebherr (Cornell University Insect Collection), Brad Hubley (Royal Ontario Museum) and Richard Brown (Mississippi State Entomological Museum) graciously hosted me on visits and provided access to specimens in their care. Lastly, photograph and data submissions by contributors to citizen science groups such as BugGuide and iNaturalist provided valuable information that aided this study.

References

- Barnes, W.M. & McDunnough, J. (1910) List of Sphingidae of America North of Mexico. *Psyche*, 17, 190–205.
<https://doi.org/10.1155/1910/54904>
- Boisduval, J.B.A. (1836) *Histoire naturelle des insectes. Species général des Lépidoptères. Vol. 1*. Librairie Encyclopédique de

- Roret, Paris, 690 pp. [Roret, Suites à Buffon]
<https://doi.org/10.5962/bhl.title.9194>
- Butler, A.G. (1874) Descriptions of new species of *Sesia* in the British Museum, *Annals and Magazine of Natural History*, 14, 365–367.
<https://doi.org/10.1080/00222937408680986>
- Butler, A.G. (1876) Revision of the Hererocerous Lepidoptera of the family Sphingidae, *Transactions of the Zoological Society of London*, 9, 511–644.
<https://doi.org/10.1111/j.1096-3642.1876.tb00236.x>
- Catling, P.M. & Brownell, V. (1999a) The alvars of the Great Lakes region. In: Anderson, R.C., Fralish, J.S. & Baskin, J.M. (Eds.), *Savanna, Barren, and Rock Outcrop Communities of North America*. Cambridge Univ. Press, Cambridge, pp. 375–391.
<https://doi.org/10.1017/CBO9780511574627.024>
- Catling, P.M. & Brownell, V. (1999b) The flora and ecology of southern Ontario granite barrens. In: Anderson, R.C., Fralish, J.S. & Baskin, J.M. (Eds.), *Savanna, Barren, and Rock Outcrop Communities of North America*. Cambridge Univ. Press, Cambridge, pp. 392–405.
<https://doi.org/10.1017/CBO9780511574627.025>
- Chapman, L.J. & Putnam, D.F. (1984) *The Physiography of Southern Ontario. Ontario Geological Survey Special Volume 23rd Edition*. Ontario Ministry of Natural Resources, Toronto, 270 pp.
- Gall, L.F. & Hawks, D.C. (2002) Systematics of moths in the genus *Catocala* (Noctuidae). III. The types of William H. Edwards, Augustus R. Grote, and Achille Guenée. *Journal of the Lepidopterists' Society*, 56, 234–264.
- Geiser, S.W. (1933) G.W. Belfrage's Texas localities, *Entomological News*, 44, 127–132.
- Grote, A.R. (1873) Descriptions of new North American moths. *Bulletin of the Buffalo Society of Natural Sciences*, 1, 1–16.
- Grote, A.R. (1874) Notes on American Lepidoptera with descriptions of twenty-one new species, *Bulletin of the Buffalo Society of Natural Sciences*, 2, 145–163.
- Grote, A.R. & Robinson, C.T. (1868) Notes on the Lepidoptera in the British Museum and described by Mr. Francis Walker, *Transactions of the American Entomological Society*, 2, 179–206.
- Handfield, L. (2011) *Les papillons du Québec*. Broquet Publishing, St-Constant, Quebec, 672 pp., 166 pls.
- Hebert, P.D.N., deWaard, J.R., Zakharov, E.V., Prosser, S.W.J., Sones, J.E., McKeown, J.T.A., Mantle, B. & La Salle, J. (2013) A DNA 'Barcode Blitz': Rapid digitization and sequencing of a natural history collection. *PLoS One*, 8, e68535.
<https://doi.org/10.1371/journal.pone.0068535>
- Hodges, R.W. (1971) *Sphingoidea. The Moths of America North of Mexico including Greenland. Fascicle 21*. E. W. Classey, London, 158 + xii pp, 14 pls.
- Huelsenbeck, J.P. & Ronquist, F. (2001) MRBAYES: Bayesian inference of phylogeny. *Bioinformatics*, 17, 754–755.
<https://doi.org/10.1093/bioinformatics/17.8.754>
- Kartesz, J.T. (2015) The Biota of North America Program (BONAP). Taxonomic Data Center. Chapel Hill, N.C. Maps generated from Kartesz, J.T. (2015). Floristic Synthesis of North America, Version 1.0. Biota of North America Program (BONAP), in press. Available from: <http://www.bonap.net/tdc> (accessed 20 February 2018)
- Kawahara, A.Y., Mignault, A.A., Regier, J.C., Kitching, I.J. & Mitter, C. (2009) Phylogeny and biogeography of hawkmoths (Lepidoptera: Sphingidae): evidence from five nuclear genes. *PLoS One*, 4 (5), e5719.
<https://doi.org/10.1371/journal.pone.0005719>
- Kitching, I.J. & Cadiou, J.M. (2000) *Hawkmoths of the world: an annotated and illustrated revisionary checklist (Lepidoptera: Sphingidae)*. Cornell University Press, Ithaca, 226 pp.
- Kumar, S., Stecher, G. & Tamura, K. (2016) MEGA7: Molecular Evolutionary Genetics Analysis version 7.0 for bigger datasets. *Molecular Biology and Evolution*, 33, 1870–1874.
<https://doi.org/10.1093/molbev/msw054>
- Lafontaine, J.D. (2004) Noctuoidea: Noctuidae (part), Noctuinae (part - Agrotini). In: Hodges, R.W. *The Moths of North America. Fasc. 27.1*. Wedge Entomological Research Foundation, Washington, D.C., pp. 1–385.
- Mallet, J. & Gilbert Jr., L.E. (1995) Why are there so many mimicry rings? Correlations between habitat, behaviour and mimicry in *Heliconius* butterflies. *Biological Journal of the Linnean Society*, 55 (2), 159–180.
<https://doi.org/10.1111/j.1095-8312.1995.tb01057.x>
- Newcomb, W.W. (1913) Checklist of Michigan Lepidoptera. II. Sphingidae. *15th Report of the Michigan Academy of Science*, 1913, 213–214.
- Plowright, R.C. & Owen, R.E. (1980) The evolutionary significance of bumble bee color patterns: a mimetic interpretation, *Evolution*, 34 (4), 622–637.
<https://doi.org/10.1111/j.1558-5646.1980.tb04002.x>
- Ratnasingham, S. & Hebert, P.D.N. (2007) BOLD: The Barcode of Life Data System *Molecular Ecology Notes*, 7 (3), 355–364.
[\[http://www.barcodinglife.org\]](http://www.barcodinglife.org)
<https://doi.org/10.1111/j.1471-8286.2007.01678.x>
- Riotte, J.C.E. (1981) Transfer of the sphingid genus *Sataspes* from the subfamily Macroglossinae to the subfamily Sphinginae (Lepidoptera: Sphingidae). *Pacific Insects*, 23 (1–2), 207–210.
- Rothschild, L.W.R. & Jordan, K. (1903) A revision of the lepidopterous family Sphingidae. *Novitates Zoologicae*, 9

(Supplement), I–CXXV + 1–972, 67 pls.

- Rubinoff, D. & Le Roux, J.J. (2008) Evidence of repeated and independent saltational evolution in a peculiar genus of sphinx moths (*Proserpinus*: Sphingidae). *PloS one*, 3 (12), e4035.
<https://doi.org/10.1371/journal.pone.0004035>
- Sbordoni, V., Bullini, L., Scarpelli, G., Forestiero, S. & Rampini, M. (1979) Mimicry in the burnet moth *Zygaena ephialtes*: population studies and evidence of a Batesian—Müllerian situation, *Ecological Entomology*, 4 (1), 83–93.
<https://doi.org/10.1111/j.1365-2311.1979.tb00563.x>
- Schmidt, B.C. (2009) *Hemaris thetis* (Boisduval, 1855) (Sphingidae) is a distinct species. *Journal of the Lepidopterists' Society*, 63 (2), 100–109.
- Smyth, E.A. (1900) Identity of *Hemaris tenuis* and *Hemaris diffinis*. *Entomologist's News*, 11, 584–589.
- Strecker, F.H.H. (1873–1877) *Lepidoptera, Rhopaloceres and Heteroceres, indigenous and exotic; with descriptions and colored illustrations*. Owen's Steam Book & Job Printing, Reading, Pennsylvania, 143 pp.
- Tuttle, J.P. (2007) *The Hawk Moths of North America. A natural history study of the Sphingidae of the United States and Canada*. Wedge Entomological Research Foundation, Washington, D.C., 253 pp.
- Wagner, D.L. (2005) *Caterpillars of eastern North America: a guide to identification and natural history*. Princeton University Press, Princeton, New Jersey, 512 pp.
- Zahiri, R., Lafontaine, J.D., Schmidt, B.C., Zakharov, E.V. & Hebert, P.D. (2017) Probing planetary biodiversity with DNA barcodes: The Noctuoidea of North America. *PloS one*, 12 (6), e0178548.
<https://doi.org/10.1371/journal.pone.0178548>