



Why is *Synedra berolinensis* so hard to classify? More on monotypic taxa

DAVID M. WILLIAMS

Department of Life Sciences, The Natural History Museum, Cromwell Road, London SW7 5BD, UK
 Email: d.m.williams@nhm.ac.uk (corresponding author)

Abstract

The diatom species *Synedra berolinensis* has been placed in the genus *Synedra*, *Fragilaria*, *Staurosira*, *Staurosirella* as well as its own monotypic genus, *Belanostrum*. It is recently returned to *Staurosirella*. This prompts a pertinent question: Why is *Synedra berolinensis* so hard to classify? One answer may be the inappropriateness of the evidence (data). Another may be the approach to classifying the organism, especially the use of monotypic taxa for problematic groups. I will address both aspects, concentrating more on the latter: How do we classify?

Key words: *Synedra berolinensis*, evidence (data), classification, monotypic taxa

Introduction

In the relatively short space of just over 20 years (1989–2003), the freshwater planktonic diatom species named *Synedra berolinensis* Lemmerm. (1900a: 31) has been shifted from *Synedra* Ehrenb. to *Fragilaria* Lyngb. (Lange-Bertalot 1989; Krammer & Lange-Bertalot 1991; Lange-Bertalot 1993), *Staurosira* Ehrenb. (Krammer & Lange-Bertalot 2000), *Staurosirella* D.M. Williams & Round (Bukhityarova 1995) and its own genus, *Belanostrum* Round & Madiana (Round & Madiana 2001), before returning to *Staurosirella* (Morales 2003) (summarised in Table 1).

TABLE 1: Generic assignments for *Synedra berolinensis* (1989–2003).

Name	Author	Reference
<i>Fragilaria berolinensis</i>	Lange-Bertalot	1989: 82, Taf. 1, figs 49–53, <i>nom. nud.</i>
<i>Fragilaria berolinensis</i>	Lange-Bertalot in Krammer & Lange-Bertalot	1991: 161, Fig. 134: 21–25, <i>nom. nud.</i>
<i>Fragilaria berolinensis</i>	Lange-Bertalot	1991: 43
<i>Staurosirella berolinensis</i>	Bukhityarova	1995: 418
	Morales	2003: 288
<i>Staurosira berolinensis</i>	Lange-Bertalot in Krammer & Lange-Bertalot	2000: 587
<i>Belanostrum berolinensis</i>	Round & Madiana	2001: 22, Figs 1–10

Synedra berolinensis is by no means the only species related to the many old fragilarioid taxa that has shifted generic position frequently: *Fragilaria shiloi* J.J. Lee, Reimer & McEnery (1980: 43), for example, has been in four genera since its discovery in 1980, including its own genus (Table 2a), and *Opephora martyi* Hérib. (1902: 43) has been in three genera including its own, with a fourth suggested (Table 2b).

Given the frequently shifting position of *Synedra berolinensis*, it seems appropriate to ask the following question: Why does it seem so hard to classify? Relevant to that question is the role of monotypic taxa, a subject I touched upon previously (Williams 2009).

First, I want to summarise the history of *Synedra berolinensis* and what we know of it before I tackle the problem of its classification.

TABLE 2: Recent generic assignments for a) *Fragilaria shiloi* (1980–2000) and b) *Opephora martyi* (1902–2006).

Name	Author	Reference
<i>Fragilaria shiloi</i>	Lee, Reimer & McEnery	1980: 43, 47; fig. 2, pl. 2, fig. 12, 13, pl. 3, fig. 20
<i>Pseudostaurosira shiloi</i>	Hallegraeff & Burford	1996: 335; fig. 5a–j
<i>Nanofrustulum shiloi</i>	F.E. Round, H. Hallsteinsen, & E. Paasche	1999: 346
“ <i>Opephora</i> ” <i>shiloi</i>	Witkowski <i>et al.</i> “...this species should be removed from <i>Fragilaria</i> . Most of the features indicate its closest relationships with <i>Opephora</i> ”	2000: 54
<i>Opephora martyi</i>	Héribaud	1902: 43, Pl. 8, fig. 20
<i>Martyana martyi</i>	(Héribaud) Round in Round, Crawford & Mann	1990: 673
<i>Fragilaria martyi</i>	(Héribaud) Lange-Bertalot	1993: 46–48; 1991: 2/3, fig. 133: 28–31
<i>Staurosirella martyi</i>	E.A. Morales & K.M. Manoylov	2006: 354

Synedra berolinensis Lemmerm.

Taxonomic history: the first 50 years

In a series of papers on planktonic algae (“Beiträge zur Kenntnis der Planktonalgen”), Ernst Lemmermann (1867–1915, for biographical data on Lemmermann see Bitter 1919) described a number of new taxa from European Lakes, some assigned to the genus *Synedra* (Lemmermann 1900a; 1900b; 1904; 1906). *Synedra berolinensis* was one of these, first presented with just a short description and no illustrations (Lemmermann 1900a). Lemmermann’s description is succinct enough to quote in full:

“Zellen 25–34 μ lang, zu 4–24 μ zu büschelförmigen, strahligen, freischwimmenden Colonien vereinigt. Valvarseite gerade, in der Mitte etwas bauchig erweitert, an den Enden 1,3 μ , in der Mitte 2, 5 μ breit. Querstreifen kurz, die Mitte nicht erreichend.”

But Lemmermann did more than simply describe new taxa. He created an additional hierarchical level in the classification of *Synedra* by placing some species—*Synedra ulna* (Nitzsch 1817: 99) Ehrenb. (1832: 87), *S. delicatissima* W. Sm. (1853: 72) and *S. acus* Kütz. (1844: 68)—in the Section (‘Sectio’ I.) Eusynedra, and his new taxa—*S. actinastroides* Lemmerm. (1900a: 30), and their varieties, and *S. berolinensis*—in a new section (‘Sectio’ II.), Belonastrum¹. Thus, Lemmermann determined what might be called two different ‘kinds’ (sub-groups) of *Synedra*, captured by his division into Sections (‘Sectio’). Of significance is not just the creation of two sections but his reasons for doing so (the evidence). Lemmermann described his two sections thus:

“I. Sectio: Eusynedra Schütt: Zellen einzeln, freischwimmend oder testsitzend” [Cells individually, free-swimming or attached]...

“II. Section: Belonastrum nob.: Zellen zur freischwimmenden, büschelförmigen, strahligen Colonien vereinigt” [Cells free-swimming, in star-shaped colonies]. (Lemmermann 1900a: 31, my translation).

1. While Mills (1933: 265–266) lists several species in this section, it is clear that he understands Lemmermann’s taxon as a section.

Lemmermann's sections were thus separated on the basis of the character 'colony formation'. That some species were found in the plankton (pelagic), an unusual (at that time) habitat for species in the genus *Synedra*, was the reason Lemmermann created his classification (summarised in Figure 1a).

(a) Lemmermann 1900a

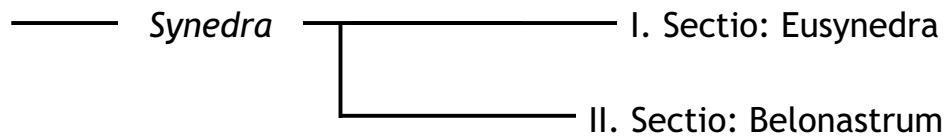

(b) Gemeinhardt 1926

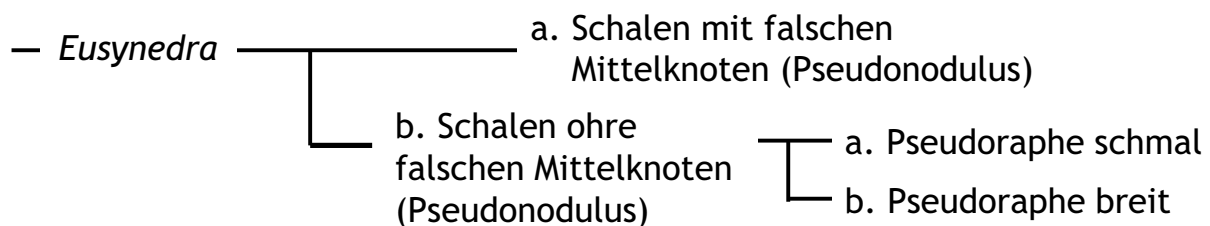

FIGURE 1. (a) Branching diagram representing the classification of *Synedra* in Lemmermann 1900a, identifying the new section ('sectio') Belonastrum. (b) Branching diagram representing the classification of *Synedra* in Gemeinhardt (1926).

In 1926 Konrad Gemeinhardt undertook a revision of *Synedra* (Gemeinhardt 1926). He placed *Synedra berlinensis*, *S. actinastroides* and *S. limnetica* Lemmerm. (1900b: 275) (all members of Lemmermann's Section Belonastrum) in his "Pseudoraphe breit" (pseudoraphe broad) sub-group, alongside *S. affinis* Kütz. (1844: 68), *S. affinis* f. *typica* Hust. (in A. Schmidt *et al.* 1914: pl. 304, figs 6–12), *S. affinis* var. *obtusa* Hust. (in A. Schmidt *et al.* 1914: pl. 304, figs 13–16) and *S. affinis* var. *fasciculata* (C. Agardh 1812: 35) Grun. in Van Heurck (1885: 153). In the "Pseudoraphe schmal" (pseudoraphe narrow) sub-group, the other half of the pair within the larger group ("Schalen ohne falschen Mittelknoten (Pseudonodulus)"—valves with 'false' central area, pseudonodulus)—Gemeinhardt placed *S. ulna* alongside species usually associated with the more 'typical' members of Eusynedra (*Synedra biceps* Kütz. (1844: 66), *S. goulardii* Bréb. (ex Cleve & Grun. 1880: 107), etc., species now understood as part of *Ulnaria* Kütz., see Williams 2011). Gemeinhardt added more characters (properties of the 'pseudoraphe' and central area) and more (un-named) divisions and sub-divisions, presenting the whole as a classification with species names appended to each sub-division (Gemeinhardt 1926: 37, see Figure 1b)².

Hustedt subsequently presented two different classifications for the sub-groups of *Synedra*. In 1930, he offered a rather complex series of sub-divisions in the form of a key (Hustedt 1930: 149–151). One of Hustedt's main sub-divisions was based on 'Apikalasche gerade...' (apical axis straight) which in turn was sub-divided into 'Zellen büschelig-mehrstrahlige, freischwimmende Kolonien bildend' and 'Zellen nicht derartige Kolonien bilden' (similar to Lemmermann's divisions). The former sub-group contained *Synedra berlinensis*, *S. actinastroides* and *S. acus*, while the latter contained all other freshwater species of *Synedra* (Figure 2a).

Yet in 1932, Hustedt presented what might be referred to as a proper classification (as opposed to his 1930 key), in which he recognised three sub-genera, *Eusynedra*, *Belonastrum* and *Ardissonia* (Figure 2b). By implication, none of Hustedt's three groups is considered to be more closely related to any other (there is no hierarchical structure to the classification beyond recognising three sub-genera). Interestingly enough, of the

2. Gemeinhardt also noted the potential of cytoplasmic characters for future classification data

sub-genus *Belonastrum*, Hustedt wrote that it “...stimmt sowohl im Bau der Zellwand als auch in der Zellform völlig mit *Eusynedra* überein, ein wesentlicher Unterschied besteht jedoch in der Koloniebildung...under der damit zusammenhängenden pelagischen Lebensweise” (Hustedt 1932: 183; “*Belonastrum* fully agrees with *Eusynedra* conforming in the structure of its valves as well as its cell. However, there exists a substantial difference in colony formation which is associated with a pelagic mode of life”, translation adapted from Jensen 1985: 170). Therefore, Hustedt explicitly agreed with Lemmermann’s viewpoint, believing that the ‘mode of life’ is sufficient grounds for recognising a sub-group, in spite of the fact that he sees ‘full’ agreement in valve structure between *Eusynedra* and *Belonastrum*. Nevertheless, he goes on to stress that the sub-genera *Belonastrum* and *Ardissonia* “...von sehr ungleichem Wert sind” (Hustedt 1932: 183, “are of very unequal merit [value]”, translation adapted from Jensen 1985: 170) without explaining the nature of that inequality.

It might be argued, with some justification, that Lemmermann, Gemeinhardt and Hustedt were simply trying to clarify how one might *identify* the various species thought to belong to *Synedra* rather than attempting to create a ‘natural’ classification (one that expresses their relationships), and their use of sections and sub-genera (as well as the many un-named subdivisions) were designed to facilitate ease of identification—as in a continually modified and updated key.

(a) Hustedt 1930

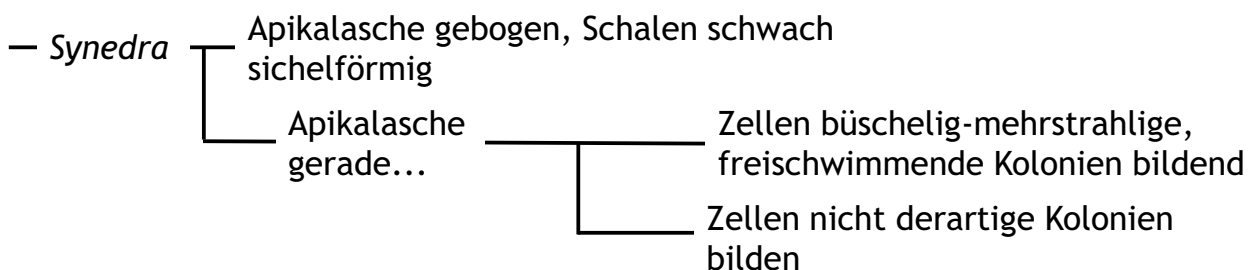

(b) Hustedt 1932

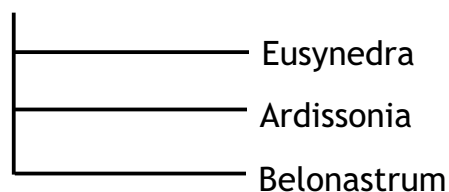

FIGURE 2. (a) Branching diagram representing the classification of *Synedra* in Hustedt (1930) and (b) Hustedt (1932).

Taxonomy and light microscope (LM) images—the data

It is worth considering for a moment just what data were available for diatomists to make their judgements. Although described in 1900, no illustrations of *Synedra berolinensis* appeared until 1904, when Lemmermann described and named a new variety of *S. berolinensis*—*S. berolinensis* var. *gracilis* Lemmerm. (1904: 310)—and offered a further brief description accompanied with some simple line drawings of both *Synedra berolinensis* (Lemmermann 1904: fig. 16, Fig. 3) and the new variety (Lemmermann 1904: fig. 17). Two years later, along with the description of *Synedra revaliensis* Lemmerm.³, Lemmermann provided a key for all of

3. This taxon was described in two different places. The exact dates of each have yet to be established.

the eight planktonic taxa he had described in the past few years that were included in his ‘Sectio’ *Belonastrum* (Lemmermann 1906; see below and the first eight entries in Table 3). But even after Lemmermann’s series of papers it appears that very few illustrations of *S. berolinensis* were published. Hustedt (in Schmidt *et al.* 1914: pl. 306, figs 17, 18), for example, illustrated two partial colonies from “Holstein” (some details of the valve structure can be appreciated from his figure 18). Hustedt reproduced these illustrations in three European floras (Hustedt 1930: 164, fig. 200; Hustedt 1932: 184, fig. 686; Hustedt 1942: 457, fig. 533, also reproduced by Cleve-Euler 1953: fig. 377a–c and Zabelina *et al.* 1951: 141, fig. 1a; the original images were derived from Hustedt’s contribution to Schmidt *Atlas* for 1914: Hustedt in A. Schmidt *et al.* 1914). Subsequently, Krieger (1927: figs 28a–h, j, k) presented some new illustrations, which Cleve-Euler reproduced in her flora (Cleve-Euler 1953: fig. 377d, e). In short, up until the mid-1950s even though *Synedra berolinensis* had been recognised for nearly half a century, it appears to have been known from only a handful of drawings, many of them being copied from one source to another as illustrations for commonly used floras.

Taxonomy and the scanning electron microscope (SEM)

One might argue that the history of *Belonastrum* above, and its interpretation, is now largely irrelevant, as many of the species thought to be *Synedra*-like (and members of the group *Belonastrum*) by Lemmermann have subsequently been placed elsewhere, such as in the very different genus *Nitzschia* Hassall, or else are now synonyms of *S. berolinensis* itself (Table 3). Nevertheless, further data became available with the introduction of scanning electron microscopy.

TABLE 3: Species described that are or have been in Section *Belonastrum* of *Synedra*. Their current name is placed in the final column, although revision might be necessary in some cases to establish the synonymy with greater certainty (indicated by double quotes).

Name	Author	Reference	Type Material	Current Name
<i>Synedra actinastroides</i>	Lemmermann	1900a:30	Not known	<i>Nitzschia fruticosa</i> (= <i>N. actinastriodes</i>)
<i>Synedra actinastroides</i> var. <i>opoliensis</i>	Lemmermann	1900a:30	Not known	<i>Nitzschia?</i>
<i>Synedra actinastroides</i> var. <i>lata</i>	Lemmermann	1900a:30	Not known	<i>Nitzschia?</i>
<i>Synedra actinastroides</i> var. <i>curvata</i>	Lemmermann	1900a:31	Not known	<i>Nitzschia?</i>
<i>Synedra berolinensis</i>	Lemmermann	1900a:31, 1904: 310, Fig. 16	Not known	“ <i>S.</i> ” <i>berolinensis</i>
<i>Synedra limnetica</i>	Lemmermann	1900b:275	Not known	“ <i>S.</i> ” <i>berolinensis</i>
<i>Synedra? asterionelloides</i>	O. Müller in Schmidle	1902:8	B 2.0004, 2.0015, 2.0019 (Jahn 2002)	<i>Nitzschia asterionellides</i>
<i>Synedra berolinensis</i> var. <i>gracilis</i>	Lemmermann	1904: 310, Fig. 17	Not known	“ <i>S.</i> ” <i>berolinensis</i>
<i>Synedra revaliensis</i>	Lemmermann	1906:536	Not known	“ <i>S.</i> ” <i>acus?</i>
<i>Synedra revaliensis</i>	Lemmermann in W. and G.S. West	1906: 110	Not known	“ <i>S.</i> ” <i>acus?</i>
<i>Synedra victoriae</i>	Woloszynska	1914: 190, Pl. 3, fig. 10	Not known	“ <i>S.</i> ” <i>berolinensis</i>
<i>Synedra utermoehlii</i>	Hustedt	1932: 185, Fig. 687	BRM K1/10: Simonsen 1987: 132, Pl. 217, Figs 1, 2; Krammer & Lange-Bertalot 1991: 452, Taf. 111, Figs 23–24	<i>Fragilaria utermoehlii</i>

According to Gaul *et al.* (1993), Cronberg (1982: Figs 164–5) provided the first SEM image of *Synedra berolinensis*, although two images presented in Round (1979: figs 1, 2) predate that paper by 3 years (it should be noted that Round did not name his taxon, writing in the plate legend “a species of the section *Belonastrum*, but not in the *Synedra* complex”). These were followed a few years later with three images published by Lange-Bertalot (1989). More recently, there have been two detailed studies, the first by Round & Maidana (2001) the other by Morales (2003), both authors coming to different conclusions. In spite of the new morphological data, Round & Maidana (2001) made their decision to place *Synedra berolinensis* in its own genus based on, among other things, its ‘habitat’ (like Hustedt earlier), while Morales (2003), after reviewing the morphological evidence, found it convincing enough to retain the species in *Staurosirella* (Round & Maidana did not present girdle band data but refer to their number), following Bukhityarova (1995: 418).

With respect to classification, this kind of approach has continued in diatom systematics up to the present, regardless of the source of data: the continual updating and modifying of generic descriptions, often discussed in terms of ‘limits’, as if definitions of taxa were like the borders of a country, occasionally expanding, occasionally contracting, depending on who was waging war (and who was ‘winning’) but retaining the same name to give the illusion of stability (or conquest).

When in doubt, or when presented with a number of apparently ‘key’ features, the taxon is often placed in a monotypic group. This process is akin to the construction of an artificial classification (keys) rather than natural classification, as a monotypic group, in this sense, is simply the sum of a set of unusual characters.

Current knowledge of Synedra berolinensis

Estimates of our current knowledge concerning *Synedra berolinensis* are hard to make and somewhat dependant on an understanding of what knowledge might mean. A rough guide can be gained from the number of citations, given that an unknown percentage of those citations might be misidentifications.

One way to ascertain citations is to use an Internet search engine where the numbers of hits may indicate a rough estimate of knowledge or applied knowledge attributed to this species. Using Google (www.google.com), roughly 16 to 17,000 hits were recovered, with considerably fewer using Bing (www.bing.com) (c. 50). With respect to searches for images, only two were found, relative to the 48 published drawings and light microscope images and 25 scanning electron microscope images (Table 4). Thus, very little actually appears to be known about *Synedra berolinensis* although, given the 17,000 records, it appears to be well known.

TABLE 4: Web search hits for the various names of *Synedra berolinensis*. Two search engines were examined, Google and Bing, hits for the latter are given in round brackets. Bing is a more conservative search engine. For the ‘Images’ column, a ‘1*’ indicates the selection of pictures from the College of Biological Sciences, University of Tsukuba website (<http://www.biol.tsukuba.ac.jp/~algae/PoK/Bacillariophyceae/Belonastrum/index.html>); the figure in square brackets is the total number of pages reported, most of which do not recover an image of *Synedra berolinensis*. In summary, only two images were found: that from College of Biological Sciences, University of Tsukuba and one other.

Name	Pages	Images
		Google (Bing)
<i>Synedra berolinensis</i>	17,500 (54)	1* [156] (1* + 1)
<i>Fragilaria berolinensis</i>	16,600 (57)	0 [16] (0)
<i>Staurosirella berolinensis</i>	16,800 (20)	0 (1*)
<i>Staurosira berolinensis</i>	29 (21)	0 (0)
<i>Belonastrum berolinensis</i>	18 (5)	1* (1)

Classification

“Is it not extraordinary that young taxonomists are trained like performing monkeys, almost wholly by imitation, and that in only the rarest cases are they given any instruction in taxonomic theory?” (Cain 1959: 243)

Cain’s viewpoint should now be considered anachronistic, gone forever. We have since learnt that there are two aspects to natural classification: groups (taxa) and evidence (characters). More precisely, evidence is required to support proposals of groups (taxa). Re-phrased as a scientific problem, the task is to establish what evidence there is for the groups we wish to recognise and what is the relationship of the evidence to the group? What data imply particular relationships (groups) so that various organisms can be collected together in species, genera, families, etc. and named? Formulated as such, the naming is no longer an art but guided by scientific principles. First I consider the relationship of evidence to the names.

Investigation of characters usually leads to the conclusion that data apply to some species in varying degrees. If Figure 3, for example, is the result of an analysis (either molecular or morphological data) a conclusion might be that there is evidence to suggest a group E–L to the exclusion of A–D (Figure 3, node 1); evidence to suggest a group E–H to the exclusion of A–D and I–L (Figure 3, node 2); evidence to suggest there is a group E–F to the exclusion of A–D and G–L (Figure 3, node 3); and so on (Figure 3, nodes 4–6). Support for nodes 1–6 can be any number of characters from 1 upwards—the number is not significant. It should be obvious that only those groups supported by evidence deserve names, so in the diagram in Figure 3 there are 7 potential groups that could be named, those that correspond to nodes 0–6. The taxonomic level is also not particularly important. For example, node 0 might be named a Class, node 1 an Order, nodes 2 and 4 Families, and nodes 3 and 5 genera (node 6 remains unnamed): data, relationships and the classification hierarchy are isomorphic—they all speak to the same thing (Table 5). The important thing—the ‘absolute standard’ (Williams 2009) if you like—is to name only the nodes, christening the evidence, as it were (Table 5). There is no fixed amount of evidence, or type of group, that corresponds to a genus: it is assigned to a particular taxonomic level, not discovered by some measure of similarity (Sato *et al.* 2008). That applies to all taxonomic levels. Therefore evidence (data) requires not simply collecting and enumerating but interpretation so that nodes may be discovered. The only significant method of character interpretation for natural classifications is cladistics, a theory of systematics outlined many years ago for diatomists that recognises synapomorphies (shared, derived characters) as support for nodes (groups, taxa) (see Kocielek *et al.* 1987 and Williams & Kocielek 2010; Williams & Ebach 2007).

TABLE 5: Classification and groups relevant to Figs 1–4.

Class		0	A–L
			A?
			B?
			C?
			D?
Order		1	E–L
	Family	2	E–I
		3	E–F (G?, H?)
	Family	4	I–L
		5	J–L

The Problem of Monotypic Taxa

Among the species in Figure 3, A–D may be understood as unusual as there is no evidence to suggest their relationships to any other taxon beyond their inclusion in the entire group, as defined by node 0 (Figure 3). As taxonomic (Linnaean) convention demands that all species have a generic name, a question may arise as to what genus A–D belong? One might be tempted to put all four together and call them a genus, basal to all other taxa. However, that would name a group for which there is no evidence—by evidence I mean characters (synapomorphies) unique to A–D. One solution would be for species A–D to each have their own monotypic generic name, which would indicate only their unknown relationships within the larger group. This may seem an excessive use of generic names but it is the only way the four species (A–D) can be recognised as distinct entities, separate from each other as well as the rest of the group, without implying relationships not supported by data. The same logic applies to taxon G and H (Figure 3; an alternative could be to assign a generic name to species E–H leaving node 3 unnamed). This appears to be the only logical use of monotypic taxa: indicators of unknown relationships.

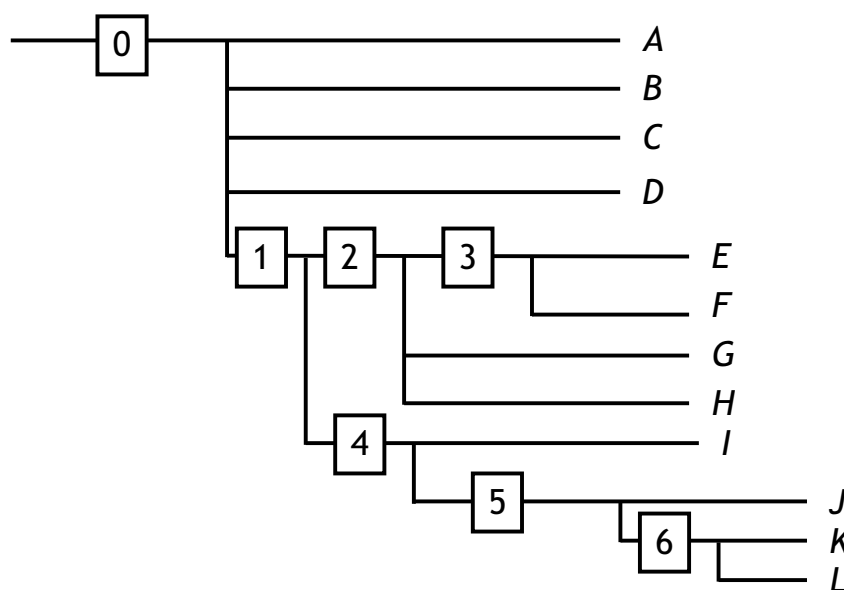

FIGURE 3. Hypothetical tree (classification) of 12 species with 7 nodes (0–6). See Table 5 and text. Node 1 suggests there is evidence to support a group E–L to the exclusion of A–D; that there is evidence to support a group E–H to the exclusion of A–D and I–L; that there is evidence to support a group E–F to the exclusion of A–D and G–L, etc., through all nodes 4–6. The assignment of taxonomic level is not particularly important (see Table 5, for an example), only the monophyly of each: data, relationships and the classification hierarchy are isomorphic.

This is not how the concept is applied generally, especially among ‘protist’ systematics (including diatoms). It is usually adopted to indicate a certain level of (unknown) measurable distinction, such that there are a number of characters (or percentage of difference) that ‘qualify’ a particular species for special treatment. A recent ‘protist’ example is worth examining in detail. In a paper published in the journal *Protist* describing some new taxa in the heterotrophic flagellate group Bicosoecida (an order of colourless, free-living protozoans), three new monotypic genera were named (Kim *et al.* 2010). Detailed morphological (ultrastructural) data was recorded but DNA sequence data was used as the primary source of evidence to determine the relationships of the three new genera relative to all other Bicosoecids. The results of their analysis were presented in a series of tree diagrams (Kim *et al.* 2010, figs 11–13). Of general interest is the relationships of *Filos* Kim, Yakubi, Leander & Graham and *Nanos* Kim, Yakubi, Leander & Graham, two of the three monotypic genera described for the first time (Kim *et al.* 2010: fig. 11 simplified here as Fig. 4). In one tree there are 13 species related to one another in varying degrees (Fig. 4); the tree is fully resolved – it

has 12 nodes (Fig. 4, nodes 0–11). Nine of the 13 species are placed in monotypic genera (Fig. 4; taxon names are followed by a figure that indicates the number of included species). What is the justification? Kim *et al.* write: “SSU rDNA gene sequence differences among these flagellates are over 8%...providing a rationale for describing them as three separate genera” (Kim *et al.* 2010: 187); and “These genetic differences are greater than those between some morphologically and ecologically *distinct* species of Chrysophyceae+Synurophyceae” (Kim *et al.* 2010: 187, my italics). One might, then, ask why 8% gene difference – why not 9%, or 10%, or 7%? Medlin (1997: 20) offers further guidance: “...values of less than 80% similarity are generally taken to indicate that separate species are involved...”. But, again, why 80%? And “generally taken”? By whom?

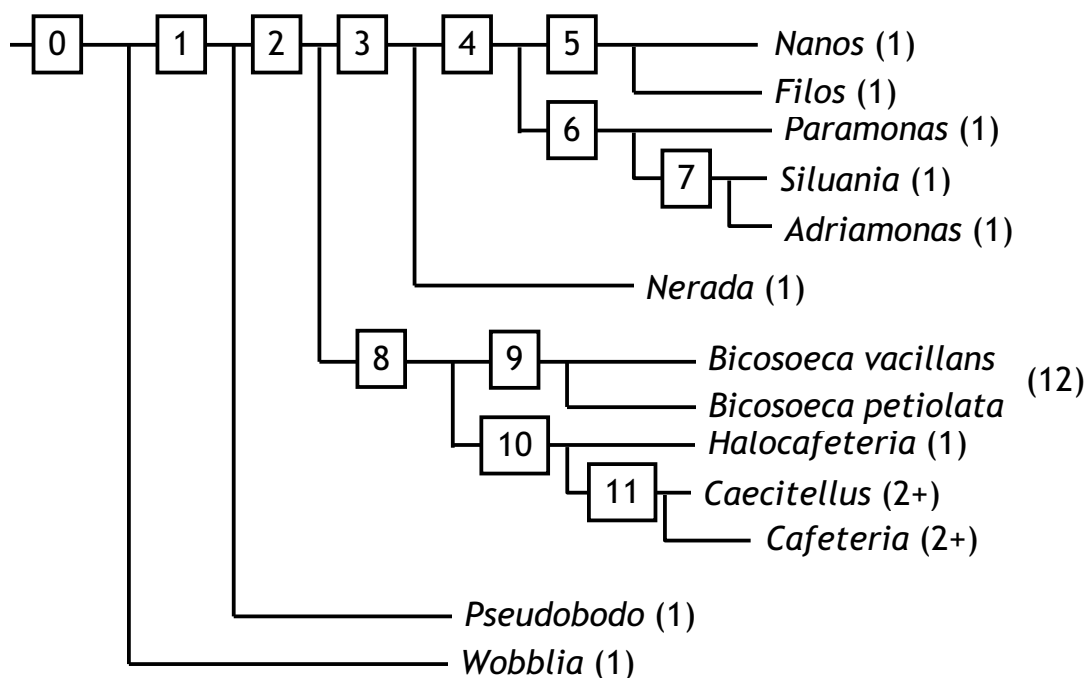

FIGURE 4. Tree representing the results of Kim *et al.* (2010: fig. 11). In this tree, there are 13 species related to one another in varying degrees; the tree is fully resolved with 12 nodes; 9 of the 13 species are monotypic genera (taxon names are followed by a figure to indicate numbers of included species).

One might contrast that effort with a recent diatom study, one already commented upon (Williams 2009). For the monotypic genus *Pseudostriatella*, Sato *et al.* suggested there were “many morphological and ecological similarities between *P. oceanica* and *S. [Striatella] unipunctata*...”, which they regarded as “sufficient to differentiate these taxa at the rank of genus” (Sato *et al.* 2008: 383). Sufficient remains undefined. They continue: “...there is no *absolute standard* for the amount of sequence difference that justifies generic status” (Sato *et al.* 2008: 386, italics mine). So, somehow, and somewhat oddly in this case, sufficiency can be estimated from morphology, whereas no such estimate can be made for the molecular data. In contrast, Kim *et al.* suggested that “*Filos agilis* and *Nanos amicus* were similar in morphology...” (Kim *et al.* 2010: 181) and “similar in morphology to *Siluania monomastiga*” (Kim *et al.* 2010: 187), but “Although *Filos*, *Nanos*, and *Siluania* share many morphological features, SSU rDNA gene sequence differences among these flagellates are over 8%...” (Kim *et al.* 2010: 187). In this case, sharing of “many morphological features” is trumped by the 8% sequence difference. None of these arguments possess any logic whatsoever – they are merely arbitrary choices plucked, as it were, from thin air.

For Kim *et al.*, as well as various diatomists, the abundance of monotypic genera is (positively) misleading with respect to classification, obscuring rather than clarifying relationships. Monotypic genera (and higher taxa) are reflections of ignorance (unknown relationships) rather than knowledge (Williams 2009).

Evidence for Classification of *Synedra berolinensis*

For evidence, I present an analysis of available molecular data relevant to the taxonomic position of *Synedra berolinensis*. This should not be taken as an exhaustive study but one undertaken simply to demonstrate some points about classification and evidence. In brief, 170 diatom SSU rRNA sequences were obtained from GenBank and aligned using BioEdit (1997–2004) from ClustalW's accessory applications (ClustalW was implemented using BioEdit's default options, Larkin *et al.* 2007). As in a previous analysis (Williams 2009), 7 species were used as outgroups: *Arcocellulus mammifer* Hasle, Stosch & Syvertsen (1983: 55), *Cymatosira belgica* Grun. in Van Heurck (1881: pl. 45, fig. 38–41), *Extubocellulus spinifer* (Hargraves & Guillard 1974: 168) Hasle, Stosch & Syvertsen (1983: 70), *Minutocellus polymorphus* (Hargraves & Guillard 1974: 166) Hasle, Stosch & Syvertsen (1983: 43), *Minutocellus* sp. CCMP1701?, *Papiliocellulus elegans* Hasle, Stosch & Syvertsen (1983: 64) and *Talaroneis posidoniae* Kooistra & Stefano (in Kooistra *et al.* 2004: 60). The final alignment yielded 2929 bases of which 2365 were uninformative, leaving 564 bases (19%) useful for determining relationships (the 'pack' option in the computer program NONA, designed to remove uninformative characters from any alignment, yielded a final matrix of 561 characters, discarding 2368, three more than Winclada for reasons that were not apparent, Nixon 1999–2002). Parsimony analysis of the 561 characters (using NONA from within Winclada, Goloboff 1999) yielded 58 trees of length 3069, a consistency index (ci) of 47 and a retention index (ri) of 84. The consensus tree of the 58 most parsimonious trees has a length of 3123, ci 46 and ri of 83, 54 steps longer than each most parsimonious tree but with nearly identical ci and ri values (alignments and Nexus files available).

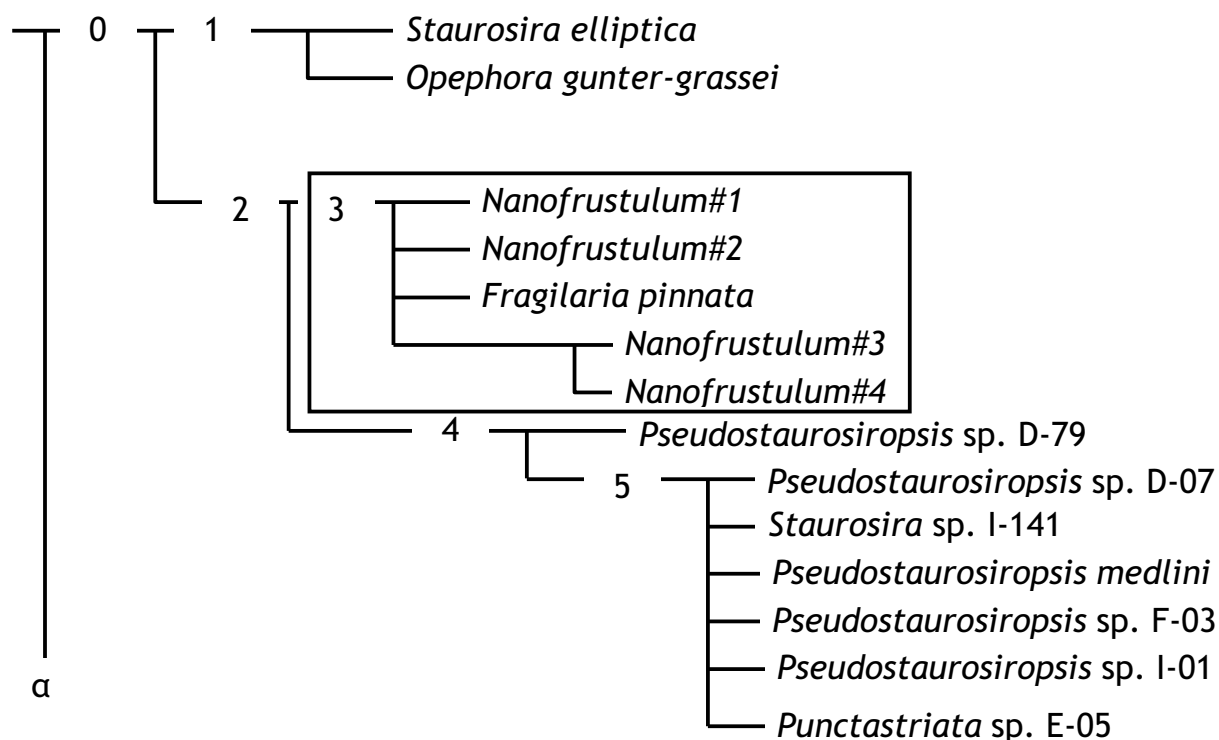

FIGURE 5. First part of one section of the consensus tree from the analysis undertaken herein, showing only taxa that related to the *Staurosira*-like groups, e.g. *Staurosira*, *Martyana*, *Staurosirella*, *Punctastriata* and *Pseudostaurosira*. The total tree (Figures 5, 6a and b) has 17 nodes (0–16). Figure 5 has nodes 0–5; this part of the tree connects to Figure 6a via the branch that terminates with the Greek letter alpha (α). Note the monophyly of *Nanofrustulum* (plus *Fragilaria pinnata*).

Only one section of the resulting consensus tree is illustrated here (the complete tree is available on request), showing only those taxa related to or thought to be related to *Staurosira*-like taxa: *Staurosira*, *Martyana* Round, *Staurosirella*, *Punctastriata* D.M. Williams & Round and *Pseudostaurosira* D.M. Williams & Round, among others. That section of the tree has 16 nodes (excluding basal node 0). For ease of

presentation, the section has been split into three parts: Fig. 5, nodes 0–5, Fig. 6a, nodes 6–10, and 6b, nodes 11–16. The tree in Fig. 5 connects to Fig. 6a via the branch that terminates with the Greek letter alpha (α); Fig. 6a joins to Fig. 6b via the branch that terminates with the Greek letter beta (β). I only briefly discuss these topologies to highlight a few general conclusions. The most obvious point to make is that with respect to the entire tree, generic names are scattered throughout the topology making its understanding less than intuitive. Clearly either current names do not reflect molecular relationships or molecular data do not reflect taxon relationships as represented by their names. Given that the morphological data remain unanalysed, it is, as yet, impossible to learn if there is any real conflict between the morphological and molecular data.

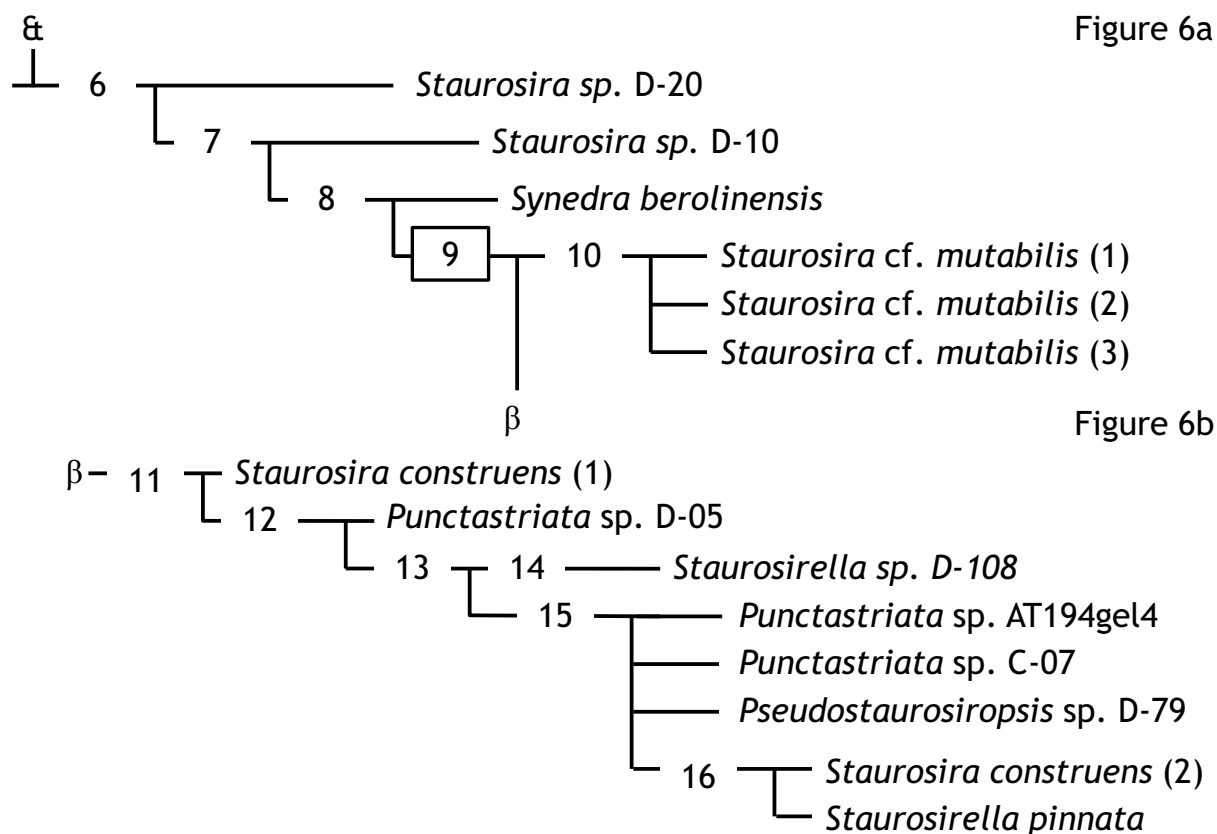

FIGURE 6. Second part of one section of the consensus tree from the analysis undertaken herein, split into two: a and b. Figure 6a joins to Figure 6b via the branch that terminates with the Greek letter beta (β). Figure 6a has nodes 6–10, Figure 6b has nodes 11–16. Note position of *Synedra berolinensis* as basal to all species from node 9.

Figure 6 has two items of interest. First, node 3 groups all the specimens named *Nanofrustulum* Round, Hallsteinsen & Paasche alongside specimens named *Fragilaria pinnata* Ehrenb. (1843: 127) (these group together in Rampen *et al.* 2007: figure 2). This offers a prediction. Investigation of the specimens named *Fragilaria pinnata* will show them to have the characters of *Nanofrustulum*—which, of course, depends on knowing the characters of *Nanofrustulum* (Witkowski *et al.* 2010; also Sar & Sunesen 2003, Li *et al.* 2008 and Morales 2001: 115). Second, node 4 groups seven species, of which 5 are named *Pseudostaurosiropsis* E. Morales (2001: 116). This provides a second prediction. The specimens named *Staurosira* sp. I-141 and *Punctastriata* sp. E-05 will be found to have the characters of *Pseudostaurosiropsis*—which also depends upon knowing the characters of *Pseudostaurosiropsis*.

Figure 7b appears to be a jumble of taxon names and few generalities can be drawn from this assemblage of species except to note that, somewhere, there is, obviously, a problem. That problem may be related to sampling, method of analysis, identification of specimens, previous characterisation of species and so on, but one must assume the problem is empirical: it can be investigated. From the perspective of the question addressed in this paper, Fig. 6a includes *Synedra berolinensis* as sister to *Staurosira* cf. *mutabilis* plus all taxa

in Fig. 6b. So: How can we classify *Synedra berolinensis* from this result?

There are a number of options all based on identifying monophyletic groups, those circumscribed by particular nodes (Williams 2009). One might be tempted to name all species from node 9 onwards as members of one genus. That would leave three basal to that group: *Synedra berolinensis*, *Staurosira* sp. D-10 and *Staurosira* sp. D-20. Assuming that the latter two names are provisional, a sensible option for the moment, would be to simply ignore them, leaving *Synedra berolinensis* basal to node 9 and the possibility of naming it as a monotypic group as its relationships beyond node 8 are unknown. Yet this seems to be unsatisfactory as the scattering of names from node 6 onwards suggests that nothing is yet really known of these relationships and, for pragmatic purposes, all the species should be in the same genus, including *Synedra berolinensis*. But this too depends on knowing the characters of the included species.

Discussion

These molecular data do not unequivocally resolve the problem of the classification of *Synedra berolinensis*. It is, of course, possible to classify the resulting tree but as can be seen above, that too is imprecise, even if proper attention is given to monotypic groups (Williams 2009).

The imprecision of these results to one side, this highlights a major drawback to molecular data: there is, as yet, no real evidence presented to support any of the nodes. In morphological systematics, when data are analysed, evidence (synapomorphies) is presented to support each node and subsequent work might focus on whether those characters are indeed synapomorphies or not: in short, the matter can be investigated. But with molecular data, there is no real evidence to support any of the nodes, or at least the evidence is not specified. With molecular studies any subsequent analyses are seen as superior simply (or usually) because there are more data and more taxa and therefore somehow must be better (Mooi and Gill 2010 and Mooi *et al.* 2011, present some general arguments critical to these matters). Thus, if node 9 was supported by some tangible data (rather than a vague statistic) one might then thereby determine whether *Synedra berolinensis* does or does not have the relevant characters.

Why is *Synedra berolinensis* so hard to classify? From the point of view of principles, it is not—just that these data, so far, are insufficient to determine its relationships. One might think, for *Synedra berolinensis* at least, it is time to return to morphology, data which, as noted above, have barely accumulated in any meaningful way. Morphology, and its analysis (the identification of synapomorphies), seems just too important to dismiss in spite of those who misunderstand its role (e.g. Mann *et al.* 2008: 66: “However, sampling for molecular analysis is still too meagre and patchy to allow us to test fully the *subjective*, morphology-based classification of British *Sellaphora* that we have given here and it will probably be several years before enough isolates of all the demes are available”, italics mine). Morphology could only be understood as ‘subjective’ as long as it remains unanalysed.

References

- Agardh, C.A. (1812) *Dispositio Algarum Suecae*. Litteris Berlingianis, Lundae, 45 pp.
<http://dx.doi.org/10.5962/bhl.title.45472>
- Bitter, F.A.G. (1919) Ernst Lemmermann. *Abhandlungen herausgegeben vom Naturwissenschaftlichen Verein zu Bremen* 24: 273–291.
- Bukhtiyarova, L.N. (1995) New taxonomical combinations of diatoms (Bacillariophyta). *Algologia* 5: 396–403.
- Cain, A.J. (1959) The post-Linnaean development of taxonomy. *Proceedings of the Linnean Society of London* 170: 234–244.
<http://dx.doi.org/10.1111/j.1095-8312.1959.tb00857.x>
- Cleve, P.T. & Grunow, A. (1880) Beiträge zur Kenntniss der Arctischen Diatomeen. *Kongliga Svenska-Vetenskaps Akademiens Handlingar* 17(2):121 pp., 7 pls.

- Cleve-Euler, A. (1953) Die Diatomeen von Schweden und Finnland. Part II, Arraphideae, Brachyraphideae. *Kongliga Svenska Vetenskaps-Akademiens Handlingar* ser. 4, 4 (1): 1–158.
- Cronberg, G. (1982) Phytoplankton changes in Lake Trummen induced by restoration. *Folia Limnologica Scandinavica* 18: 1–119.
- Ehrenberg, C.G. (1832) Über die Entwicklung und Lebensdauer der Infusionsthier; nebst ferneren Beiträgen zu einer Vergleichung ihrer organischen Systeme. *Abhandlungen der Königlichen Akademie der Wissenschaften zu Berlin* 1831: 1–154, 4 pls.
- Ehrenberg, C.G. (1843) Verbreitung und Einfluss des mikroskopischen Lebens in Süd- und Nord-Amerika. *Abhandlungen der Königlichen Akademie der Wissenschaften zu Berlin* 1841: 291–445, 4 pls.
- Gaul, U., Geissler, U., Henderson, M., Mahoney, R. & Reimer, C.W. (1993) Bibliography on the fine-structure of diatom frustules (Bacillariophyceae). *Proceedings of the Academy of Natural Sciences, Philadelphia* 144: 69–238.
<http://www.jstor.org/stable/4065006>
- Gemeinhardt, K. (1926) Die Gattung *Synedra* in systematischer, zytologischer und ökologischer Beziehung. *Pflanzenforschung* 6: 1–88.
- Goloboff, P. (1999) *NONA (NO NAME) ver. 2*. Published by the author, Tucumán, Argentina.
- Hallegraeff, G.M. & Burford, M.A. (1996) Some new or little known nanoplankton diatom cultured from tropical and subtropical Australian shelf waters. *Nova Hedwigia, Beiheft* 112: 329–342.
- Hargraves, P.E. & Guillard, R.R.L. (1974) Structural and physiological observations on some small marine diatoms. *Phycologia* 13:163–172.
<http://dx.doi.org/10.2216/i0031-8884-13-2-163.1>
- Hasle, G.R., Stosch, H.A. von and Syvertsen, E.E. (1983) Cymatosiraceae, a new diatom family. *Bacillaria* 6: 9–156.
- Héribaude, J. (1902) *Les Diatomées Fossiles d'Auvergne*. Librairie des Sciences Naturelles, Paris.
- Héribaude, J. (1903) *Les Diatomées Fossiles d'Auvergne*. [Second Mémoire] Librairie des Sciences Naturelles, Paris.
- Hustedt, F. (1930) Bacillariophyta (Diatomeae), in: Pascher, A. (ed.) *Die Süßwasser-Flora Mitteleuropas*, Zweite Auflage, vol. 10, 1–466, Jena, Gustav Fischer.
- Hustedt, F. (1932) Die Kieselalgen Deutschlands, Oesterreichs und der Schweiz unter Berücksichtigung der übrigen Länder Europas sowie der angrenzenden Meeresgebiete, in Rabenhorst, L. (ed.), *Krypogamen-Flora von Deutschland, Osterreich und der Schweiz*, Band 7(2), 177–320, Leipzig, R. Reisland.
- Hustedt, F. (1942) Diatomeen, in: Thienemann, A. (ed.), *Die Binnengewässer, Einzeldarstellungen aus der Limnologie und ihren Nachbargebieten von G. Huber-Pestalozzi, Das Phytoplankton des Süßwassers, Systematik und Biologie*, volume 16, 367–549, Stuttgart, E. Schweizerbart'sche Verlagsbuchhandlung.
- Jahn, R. (2002) Otto Müller's names of diatoms (Bacillariophyceae) and extant original material at the Botanical Museum Berlin-Dahlem (B). *Willdenowia* 32: 155–173.
- Jensen, N.G. (1985) *The Pennate diatoms: A translation of Hustedt's "Die Kieselalgen, 2. Teil", with a supplement by Norman G. Jensen*. Koenigstein, Koeltz Scientific Books.
- Kim, E., Yubukib, N., Leander, B.S. & Graham, L. E. (2010) Ultrastructure and 18S rDNA Phylogeny of *Apoikia lindahlia* comb. nov. (Chrysophyceae) and its epibiotic protists, *Filos agilis* gen. et sp. nov. (Bicosoecida) and *Nanos amicus* gen. et sp. nov. (Bicosoecida). *Protist* 161: 177–196.
<http://dx.doi.org/10.1016/j.protis.2009.09.003>
- Kocielek, J.P., Theriot, E.C. & Williams, D.M. (1987) Inferring diatom phylogeny: A cladistic perspective. *Diatom Research* 4: 289–300.
<http://dx.doi.org/10.1080/0269249X.1989.9705077>
- Kooistra, W., Forlani, G., Sterrenburg, F.A.S. and De Stefano, M. (2004). Molecular phylogeny and morphology of the marine diatom *Talaroneis posidoniae* gen. sp. nov. (Bacillariophyta) advocate the return of the Plagiogrammaceae to the pennate diatoms. *Phycologia* 43: 58–67.
<http://dx.doi.org/10.2216/i0031-8884-43-1-58.1>
- Krammer, K. & Lange-Bertalot, H. (1991) Süßwasserflora von Mitteleuropa. Bacillariophyceae 3. Teil: Centrales, Fragilariaceae, Eunotiaceae, In: Ettl, H., Gerloff, J., Heynig, H. & Mollenhauer, D. (eds), *Süßwasserflora von Mitteleuropa*, 2 (3), Stuttgart & Jena, G. Fischer.
- Krammer, K. & Lange-Bertalot, H. (2000) Süßwasserflora von Mitteleuropa. Bacillariophyceae 3 [2nd edition]. Teil: Centrales, Fragilariaceae, Eunotiaceae, in: *Süßwasserflora von Mitteleuropa* Ettl, H., Gerloff, J., Heynig, H. & Mollenhauer, D. (eds), 2 (3), Spektrum Akademischer Verlag, Heidelberg & Berlin.
- Krieger, W. (1927) Zur Biologie des Flussplanktons. Untersuchungen über das Potamoplankton des Havelgebietes. *Pflanzenforschung* 10: 1–61.
- Kützing, F.T. (1844) *Die Kieselalgen. Bacillarien oder Diatomeen*. Nordhausen. 152 pp., 30 pls
- Lange-Bertalot, H. (1989) Können *Staurosirella*, *Punctastriata* und weitere Taxa sensu Williams & Round als Gattungen der Fragilariaceae kritischer Prüfung standhalten? *Nova Hedwigia* 49: 79–106.
- Lange-Bertalot, H. (1993) 85 neue taxa und über 100 weitere neu definierte Taxa ergänzend zur Süßwasserflora von

Mitteleuropa Vol. 2/1-4. *Bibliotheca Diatomologica* 27.

- Larkin, M.A., Blackshields, G., Brown, N.P., Chenna, R., McGettigan, P.A., McWilliam, H., Valentin, F., Wallace, I.M., Wilm, A., Lopez, R., Thompson, J.D., Gibson, T.J., & Higgins, D.G. (2007) Clustal W and Clustal X version 2.0. *Bioinformatics* 23:2947–2948.
<http://dx.doi.org/10.1093/bioinformatics/btm404>
- Lee, J.J., Reimer, C.W. & McEnery, M.E. (1980) The identification of diatoms isolated as endosymbionts from larger Foraminifera from the Gulf of Eilat (Red Sea) and the description of 2 new species, *Fragilaria shiloi* sp. nov. and *Navicula reisii* sp. nov. *Botanica marina* 23: 41–48.
- Lemmermann, E. (1900a) Beiträge zur Kenntnis der Planktonalgen. III. Neue Schwebalgen aus der Umgegend von Berlin. *Bericht der Deutschen Botanischen Gessellschaft* 18: 24–32.
- Lemmermann, E. (1900b) Beiträge zur Kenntnis der Planktonalgen. IX. *Lagerheimia marssonii* nov. spec., *Centrtractus belonophora* (Schmidle) nov. gen. et spec., *Synedra limnetica* nov. spec., *Marssoniella elegans* nov. gen. et spec. *Bericht der Deutschen Botanischen Gessellschaft* 18: 272–275.
- Lemmermann, E. (1904) Beiträge zur Kenntnis der Planktonalgen. XIX. Das Phytoplankton der Ausgrabenseen bei Plön. *Forschungsberichte aus der Biologischen Station zu Plön* 11: 289–311.
- Lemmermann, E. (1906) Belonastrum-Gruppe: *Synedra revalensis*. *Bericht der Deutschen Botanischen Gessellschaft* 24: 537–538.
- Li, Y., Gao, Y.-H. & Lü, S.-H. (2008) *Nanofrustulum*, a new record of nanodiatom genus in China. *Journal of Systematics & Evolution* 46: 750–753.
- Mann, D.G., Thomas, S.J. & Evans, K.M. (2008) Revision of the diatom genus *Sellaphora*: a first account of the larger species in the British Isles. *Fottea* 8: 15–78.
- Medlin, L.K. (1997) Can molecular techniques help define species limits? *Diatom* 13: 19–23.
- Mooi, R.D. & Gill, A.C. (2010) Phylogenies without synapomorphies—A crisis in fish systematics: Time to show some character. *Zootaxa* 2450: 26–40.
- Mooi, R.D., Williams, D.M. & Gill, A.C. (2011) Numerical cladistics, an unintentional refuge for phenetics – a reply to Wiley *et al.* *Zootaxa* 2946: 17–28
- Morales, E.A. (2001) Morphological studies in selected fragilaroid diatoms (Bacillariophyceae) from Connecticut waters (U.S.A.). *Proceedings of the Academy of Natural Sciences, Philadelphia* 151: 105–120.
[http://dx.doi.org/10.1635/0097-3157\(2001\)151\[0105:MSISFD\]2.0.CO;2](http://dx.doi.org/10.1635/0097-3157(2001)151[0105:MSISFD]2.0.CO;2)
- Morales, E.A. (2003) On the taxonomic status of the genera *Belonastrum* and *Synedrella* proposed by Round and Maidana (2001). *Cryptogamie Algologie* 24: 277–288.
- Morales, E.A. & Manoylov, K.M. (2006) *Staurosirella incognita* Morales et Monoylov sp. nov., a non-spiny species from North America, with an emended description of *Staurosirella* Williams et Round (Bacillariophyceae), in: Witkowski, A. (ed.), *Proceedings of the 18th International Diatom Symposium*, pp. 325–326.
- Nitzsch, C.L. (1817) Beitrag zur Infusorienkunde oder Naturbeschreibung der Zerkarien und Bazillarien. *Neue Schriften der naturforschenden Gesellschaft zu Halle* 3(1):128 pp., 6 pls.
- Nixon, K.C. (1999–2002) *WinClada ver. 1.0000*. Published by the author, Ithaca, NY, USA.
- Round, F.E. (1979) The classification of the genus *Synedra*. *Nova Hedwigia, Beiheft* 64: 135–146.
- Round, F. E., Crawford, R.M. & Mann, D.G. (1990) *The Diatoms - Biology and morphology of the genera*. Cambridge, Cambridge University Press.
- Round, F.E., Hallsteinsen, H. & Paasche, E. (1999) On a previously controversial “fragilaroid” diatom now placed in a new genus *Nanofrustulum*. *Diatom Research* 14: 343–356.
<http://dx.doi.org/10.1080/0269249X.1999.9705476>
- Round, F.E. & Maidana, N.I. (2001) Two problematic freshwater araphid taxa re-classified in new genera. *Diatom* 17: 21–28.
- Sar, E.A. & Sunesen, I. (2003) *Nanofrustulum shiloi* (Bacillariophyceae from the Gulf of San Matías (Argentina): Morphology, distribution and comments about nomenclature. *Nova Hedwigia* 77: 399–406.
<http://dx.doi.org/10.1127/0029-5035/2003/0077-0399>
- Sato, S., Mann, D.G., Matsumoto, S. & Medlin, L.K. (2008) *Pseudostriatella* (Bacillariophyta): a description of a new araphid diatom genus based on observations of frustule and auxospore structure and 18S rDNA phylogeny. *Phycologia* 47: 371–391.
<http://dx.doi.org/10.2216/08-02.1>
- Schmidt, A. *et al.* (1914) (eds) *Atlas der Diatomaceenkunde* Leipzig, R. Reisland, Series VII (Heft 76):pls. 301–304.
- Simonsen, R. (1987) *Atlas and catalogue of the diatom types of Friedrich Hustedt*. Berlin & Stuttgart, J. Cramer.
- Smith, W. (1853) *Synopsis of British Diatomaceae*, volume 1. John Van Voorst, London.
- Van Heurck, H. (1881) *Synopsis des Diatomées de Belgique*. Atlas. Ducaju & Cie., Anvers. pls 31–77.
- Van Heurck, H. (1885) *Synopsis des Diatomées de Belgique*. Texte. Martin Brouwers & Co., Anvers. 235 pp.
- Williams, D.M. (2009) ‘Araphid’ diatom classification and the ‘Absolute Standard’. *Acta Botanica Croatica* 68: 455–

- Williams, D.M. (2011) *Synedra*, *Ulnaria*: definitions and descriptions – a partial resolution. *Diatom Research* 26: 149–153.
<http://dx.doi.org/10.1080/0269249X.2011.587646>
- Williams, D.M. & Ebach, M.C. (2007) *The Foundations of Systematics & Biogeography*. Springer.
- Williams, D.M. & Kociolek, J.P. (2011) An overview of diatom classification with some prospects for the future, in: Seckbach, J. & Kociolek, J.P. (Eds), *The Diatom World*, Dordrecht, The Netherlands, Springer, pp. 47–91.
http://dx.doi.org/10.1007/978-94-007-1327-7_3
- Witkowski, A., Lange-Bertalot, H. & Metzeltin, D. (2000) Diatom flora of marine coasts I. *Iconographia Diatomologica* 7.
- Witkowski, A., Riaux-Gobin, C. & Daniszewska-Kowalczyk, G. (2010) New marine littoral diatom species (Bacillariophyta) from Kerguelen Islands. II. Heteropolar species of Fragilariaceae. *Vie et Milieu—Life & Environment* 60: 265–281.
- Zabelina, M., Kiselev, M., Proshkina-Lavrenko, I.A. & Sheshukova, V.S. (1951) *Diatomovie Vodorosli. Opredelitel' Presnovodnyh Vodoroslej SSSR*, 4, Moskwa, Nauka.